



Features

- Spread Spectrum Crystal oscillator (Programmable)
- 0.25~160MHz Output Frequency range
- Operating voltages: 1.62 V to 3.63V
- Operating temperature: -40°C to +125°C
- Configurable spread spectrum settings:
7 kinds of spread:
 $\pm 0.0625\%$, $\pm 0.125\%$, $\pm 0.25\%$, $\pm 0.5\%$, $\pm 1\%$, $\pm 1.5\%$, $\pm 2.0\%$
- OE disable function
- 3 kinds of Rise time/Fall time:
Default mode, Fast mode and Slow mode
- Modulation Frequency: $F_{IN}/804$
- Spread Profile: Triangle
- Used for Fundamental Crystal Oscillator
- Used for 7050/5032/3225/2520 package

Benefits

- Reduction in EMI
- System cost saving
- Reduced system complexity
- Faster time to market

Description

The XO6502C are Programmable Crystal Oscillator series with CMOS output.

This series offer the easy programmability of frequencies and other parameters, they also have a wider operating temperature range, from -40°C to +125°C. In addition to a 2.5 × 2.0 mm package that will enable electronics manufacturers to save board space, the oscillators will also be available in the following popular package sizes: 3.2 × 2.5 mm, 5.0 × 3.2 mm and 7.0 × 5.0 mm. Users will be able to program the products to the required output frequency, as well as to the required spread spectrum settings.

This will also significantly contribute to performance, lower power requirements, fast development cycles, and low-volume production.

Applications

- IP Camera
- Printers/MFPs
- Media players
- DTV/Set-top Box
- Embedded digital video devices
- LCD Panel Modules
- Automotive components
- Networking devices
- Surveillance

Block Diagram

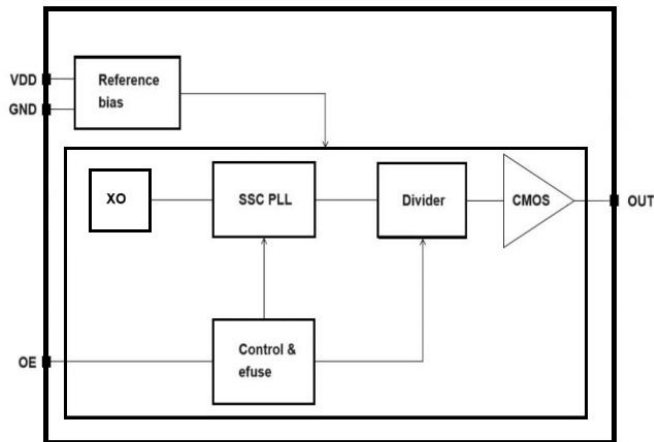



Outline Drawing and Terminal Assignment

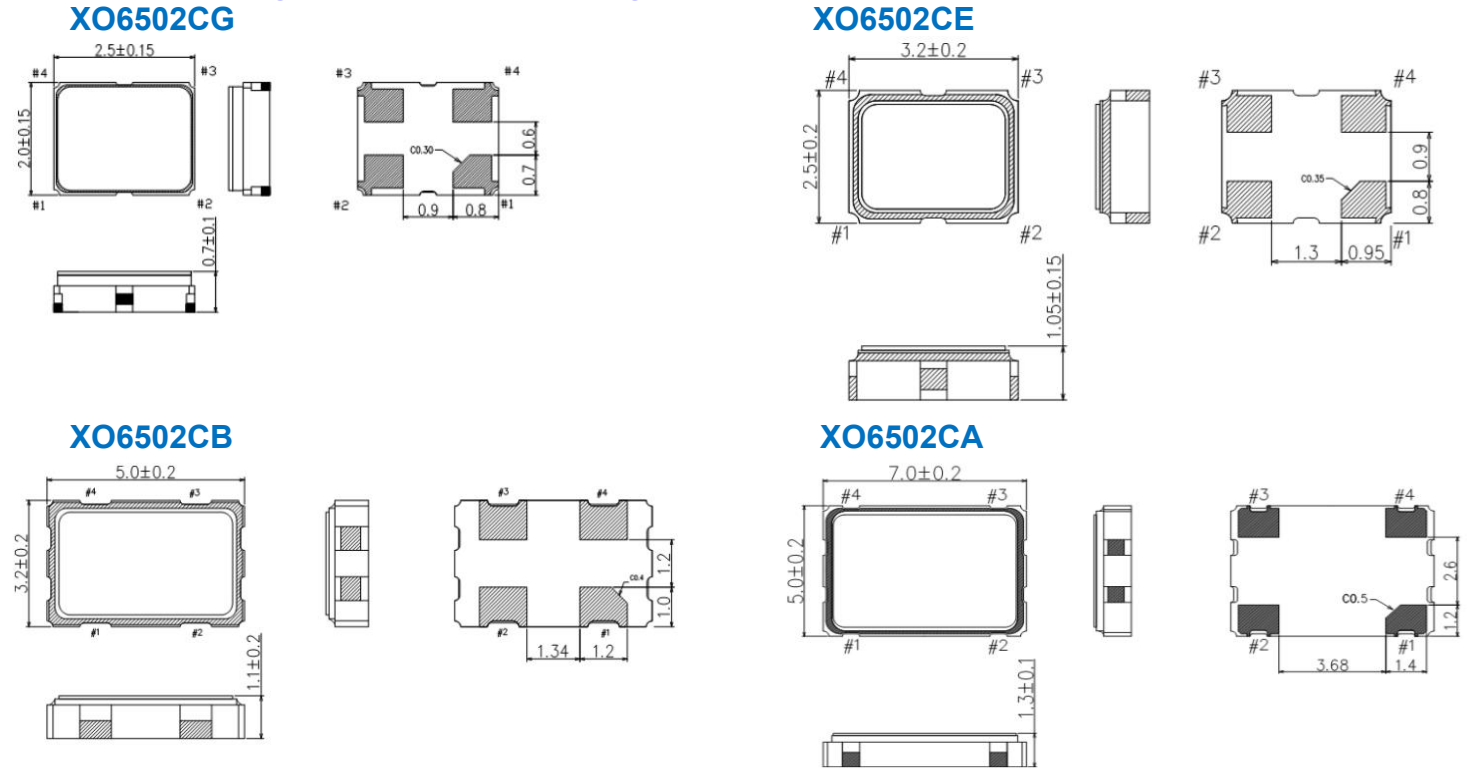

Pin #	Connection	Function		
#1	OE*	OE terminal		
		OE function	Osc. Circuit	Output
		“H”	Oscillation	Specified frequency: Enable
		“L”	Oscillation	Low (weak pull down): Disable
	\overline{ST} *	\overline{ST} terminal		
		\overline{ST} function	Osc. Circuit	Output
“H”		Oscillation	Specified frequency: Enable	
		“L”	Oscillation Stop	Low (weak pull down): Disable
#2	GND	GND terminal		
#3	OUT	Output terminal		
#4	V _{DD}	V _{DD} Terminal		

Note: * Please do not use the OE/ \overline{ST} terminal in the open state.



Order Information

XO6502C - A - 25.000000 MHz - C - 20 - P - H - A
 ① ② ③ ④ ⑤ ⑥ ⑦ ⑧

①: Model ②: Size ③: Output Frequency ④: Spread type ⑤: Spread width
 ⑥: Function ⑦: Operating temperature ⑧: Rise time/Fall time

②: Size	
G	2.5mm × 2.0mm
E	3.2mm × 2.5mm
B	5.0mm × 3.2mm
A	7.0mm × 5.0mm

④: Spread type	
C	Center Spread
D	Down Spread

⑥: Function	
P	Output enable(1#pin=OE)
S	Standby(1#pin=ST)

⑤: Spread width		
	Center Spread	Down Spread
06	±0.0625%	-
12	±0.125%	-
02	±0.25%	-
05	±0.5%	-
10	±1.0%	-
15	±1.5%	-
20	±2.0%	-

⑦: Operating temperature	
G	-40°C to +85°C
H	-40°C to +105°C
A	-40°C to +125°C

⑧: Rise time/Fall time	
A	Default
B	Fast
C	Slow



Maximum Rating

Supply Voltage to Ground Potential.....	4V
OE/ \overline{ST} pin	$V_{DD}+0.3V$
Storage Temperature.....	-40°C to +125°C

Note:
Stresses greater than those listed under MAXIMUM RATINGS may cause permanent damage to the device. This is a stress rating only and functional operation of the device at these or any other conditions above those indicated in the operational sections of this specification is not implied. Exposure to absolute maximum rating conditions for extended periods may affect reliability.

Recommended Operating Conditions

(GND=0V, unless otherwise noted.)

Sym.	Parameter	Conditions	Min	Typ	Max	Unit
V_{DD}	Supply voltage	-	1.62	-	3.63	V
V_{IN}	Input voltage	OE/ \overline{ST} terminal	0	-	V_{DD}	V
T_A	Operating temperature	-	-40	25	+85	°C
		-	-40	25	+125	°C
L_{CMOS}	CMOS load condition	-	-	-	15	pf

Note:
* 0.1 μ F or over bypass capacitor should be connected between VCC and GND pins located close to the device

Frequency Characteristics

Sym.	Parameter	Conditions	Min	Typ	Max	Unit
F_O	Output frequency	OE/ \overline{ST} terminal	0.25	-	160	MHz
F_{tol}	Frequency tolerance *1	-	-50	-	50	ppm
F_{age}	Frequency aging	-	Included in frequency tolerance			ppm

Note:
*1: Frequency tolerance includes initial frequency tolerance, frequency / temperature characteristics, frequency / voltage coefficient, frequency / load coefficient and frequency aging (+25 °C, first year)



DC Characteristics

V_{DD}= 1.62V to 3.63V, Ambient Temperature -40 to +125°C

Symbol	Parameter	Conditions	Min.	Typ.	Max.	Unit		
I _{DD}	Current consumption	V _{DD} =1.8V No load	2MHz		5.02		mA	
			10MHz	-	5.8		mA	
			25MHz	-	6.2		mA	
			50MHz	-	6.6		mA	
			100MHz	-	7.4		mA	
			160MHz	-	8.1		mA	
		V _{DD} =2.5V No load	2MHz			5.03		mA
			10MHz	-		6.4		mA
			25MHz	-		6.91		mA
			50MHz	-		7.4		mA
			100MHz	-		8.3		mA
			160MHz	-		9.3		mA
		V _{DD} =3.3V No load	2MHz			5.04		mA
			10MHz			6.6		mA
			25MHz			7.2		mA
			50MHz			7.8		mA
			100MHz			9.1		mA
			160MHz			10.4		mA
I _{DIS}	Disable current	V _{DD} =1.8V			5.9	mA		
		V _{DD} =2.5V			6.6	mA		
		V _{DD} =3.3V			6.7	mA		
I _{STD}	Standby current	V _{DD} =1.8V	-		1	mA		
		V _{DD} =2.5V	-		1	mA		
		V _{DD} =3.3V	-		1	mA		
V _{OH}	Output high voltage	V _{DD} =1.8V, I _{OH} = -2.5mA	0.9V _{DD}	-	-	V		
		V _{DD} =2.5V, I _{OH} = -4.0mA						
		V _{DD} =3.3V, I _{OH} = -5.0mA						
V _{OL}	Output low voltage	V _{DD} =1.8V, I _{OL} = 2.5mA	-	-	0.15V _{DD}	V		
		V _{DD} =2.5V, I _{OL} = 4.0mA						
		V _{DD} =3.3V, I _{OL} = 5.0mA						
V _{IH}	HIGH level input voltage	OE/ \overline{ST} terminal	0.8V _{DD}	-		V		
V _{IL}	LOW level input voltage	OE/ \overline{ST} terminal	-	-	0.2V _{DD}	V		
C _{IN}	Input pull-up resistance	OE/ \overline{ST} terminal	-	2.5	5	pf		
R _{UP1}	Input pull-up resistance	OE/ \overline{ST} = 80 % V _{DD}	20	-	150	k Ω		
R _{UP2}		OE/ \overline{ST} = 20 % V _{DD}	5	-	60	M Ω		
R _{DN}	Output pull-down	OE/ \overline{ST} = GND, OUT = V _{DD}	0.5		5	M Ω		



AC Characteristics

V_{DD}= 1.62V to 3.63V, Ambient Temperature -40 to +125°C

Symbol	Parameter	Conditions	Min.	Typ.	Max.	Unit	
T _{STR}	Start-up time	V _{DD} >1.62V	-	6	10	ms	
Duty cycle	Output duty cycle	Load=15pf, 50%V _{DD}	45	50	55	%	
Tr/Tf	Rise time/Fall time (20%V _{DD} ~80%V _{DD})	fo ≤ 20 MHz (Slow mode)			10	ns	
		fo ≤ 40 MHz (Default)			6	ns	
		fo > 40 MHz (Default)			3	ns	
		Fast mode			3	ns	
Tstp_OE	Output disable time (OE)	OE terminal HIGH → LOW			1	μs	
Tstp_ST	Output disable time (ST)	\overline{ST} terminal HIGH → LOW			1	μs	
Tsta_OE	Output enable time (OE)	OE terminal LOW → HIGH			1	μs	
Tsta_ST	Output enable time (ST)	\overline{ST} terminal LOW → HIGH			3	ms	
t _{c-c}	Cycle to Cycle jitter (Clock cycle > 50 000)	V _{DD} =1.8V load=15pf	10MHz			312.1	ps
			20MHz			225.3	ps
			50MHz			91.7	ps
			100MHz			70.4	ps
			160MHz			65.6	ps
		V _{DD} =2.5V load=15pf	10MHz			292.9	ps
			20MHz			136.6	ps
			50MHz			48.7	ps
			100MHz			37.6	ps
			160MHz			40	ps
		V _{DD} =3.3V load=15pf	10MHz			290.1	ps
			20MHz			128.8	ps
			50MHz			44.6	ps
			100MHz			31.3	ps
			160MHz			29.5	ps
fmod	Modulation frequency			F _{in} /804		KHz	

Note: Typical condition is on room temperature at 25°



Thermal resistance (For reference only)

Symbol	Parameter	Condition	Datasheet			Unit
			Min.	Typ.	Max.	
Tj	Junction temperature				+125	°C
θ_{jc}	Junction to case	XO6502CG	-	15.2	-	°C/W
		XO6502CE	-	23.1	-	
		XO6502CB	-	16.1	-	
		XO6502CA	-	28.0	-	
θ_{ja}	Junction to ambient	XO6502CG	-	91.9	-	°C/W
		XO6502CE	-	103.8	-	
		XO6502CB	-	82.5	-	
		XO6502CA	-	78.8	-	



Measurement Circuit

Waveform Observation

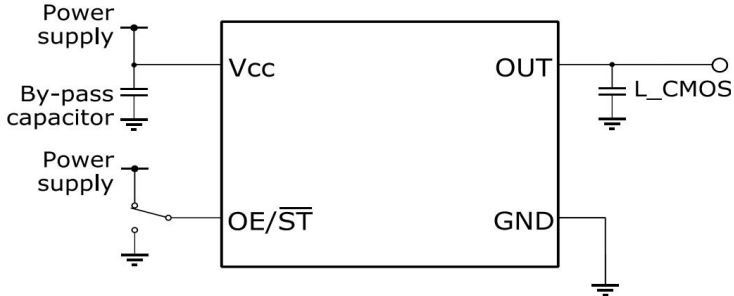

Current Consumption Test

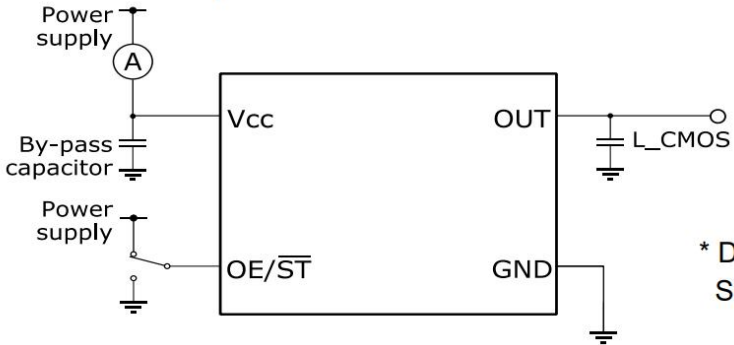

* Disable current test should be OE = GND.
Stand-by current test should be \overline{ST} = GND.

Phase Jitter

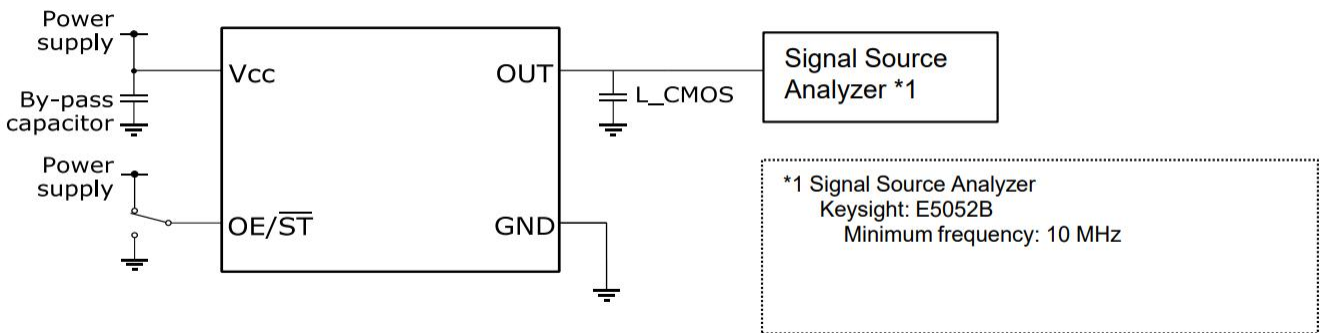



Jitter (Peak to Peak, RMS, Cycle to Cycle)

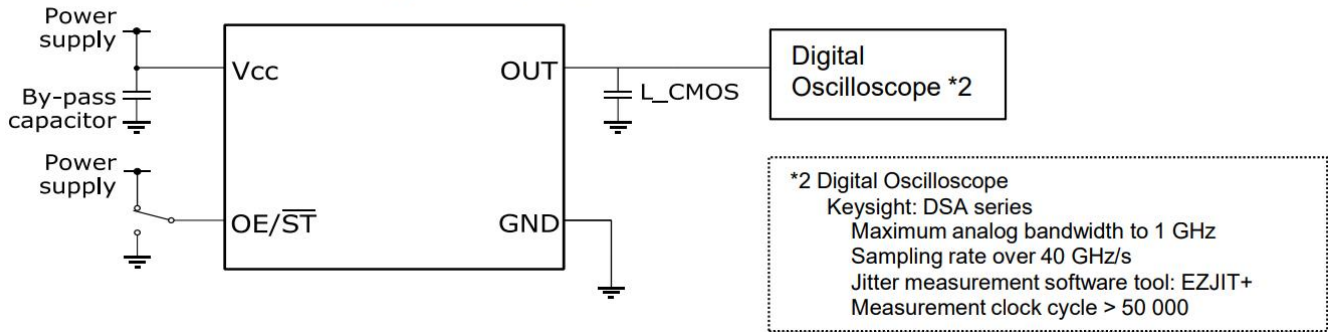

Note:

1. Oscilloscope The bandwidth should be minimum 5 times wider than measurement frequency The probe ground should be placed closely to the test point and the lead length should be as short as possible * It is recommended to use miniature socket. Don't use earth lead.)
2. L_CMOS includes probe capacitance.
3. 0.1µF bypass capacitor should be connected between VCC and GND pins located close to the device
4. Use a current meter with a low internal impedance
5. Power Supply Power supply startup time (0 %VCC → 90 %VCC) should be between 5 µs and 500 ms Power supply impedance should be as low as possible and GND line should be as short as possible

Timing Chart

(1) Output Waveform and Level

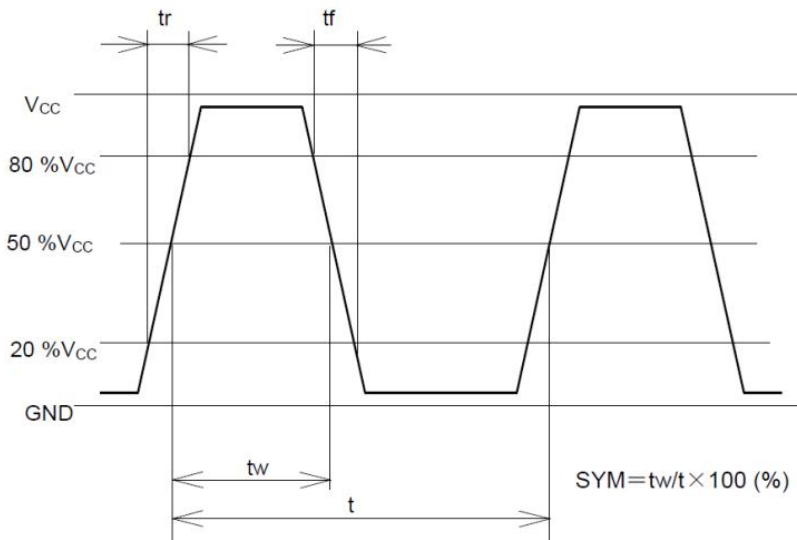



(2) OE/ \overline{ST} Function and Timing

OE/ \overline{ST} terminal	Osc. circuit	Output status
"H"	Oscillation	Specified frequency: Enable
"L"	OE: Oscillation	Low (Weak pull down ^{*3}): Disable
	\overline{ST} : Oscillation stop	

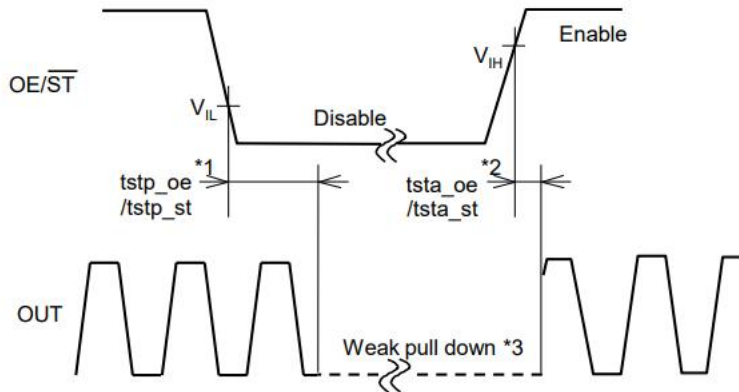

*1 The period from OE/ \overline{ST} = V_{IL} to OUT = Low (weak pull down) (Disable)

*2 The period from OE/ \overline{ST} = V_{IH} to OUT = Enable

*3 Pulled down with Output pull down resistance (R_{DN})

* Judging the start of output when output waveform is observed.

* OE/ \overline{ST} terminal voltage level should not exceed supply voltage when using OE/ \overline{ST} function.
Please note that OE/ \overline{ST} rise time should not exceed supply voltage rise time at the start-up.

* Please do not use the OE/ \overline{ST} terminal in the open state.

Typically the output will be enable when OE/ \overline{ST} is open state, but the input pull resistance is large and OE/ \overline{ST} terminal may drop to "L" level and be disable due to noise or leakage current.

3) Triangle

Center spread, spread width: $\pm 0.5\%$

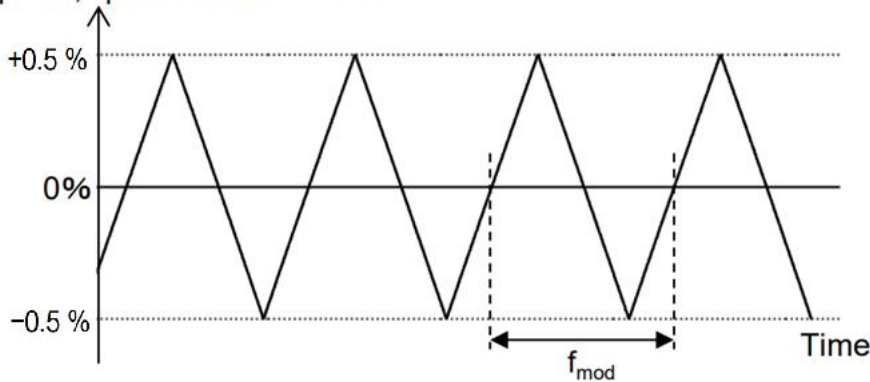



Application Circuit

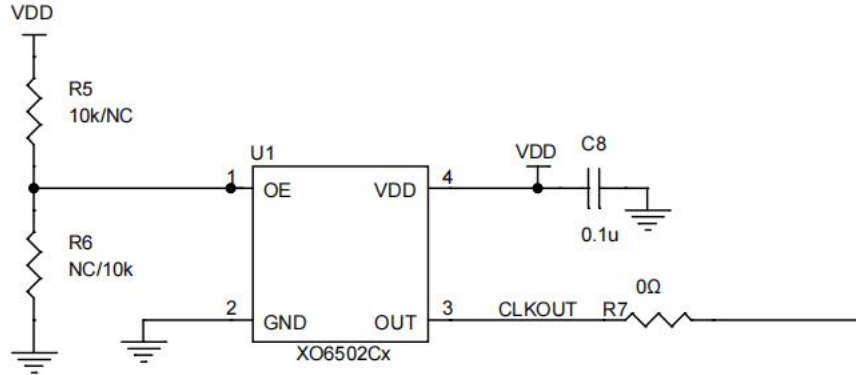

Revision History

Revision	Description	Date
0.9	Preliminary Datasheet Initiated	2025/2/25
1.0	Initial release	2025/5/7
1.1	Update Start-up time	2026/6/26