



Features

- Spread Spectrum IC (Programmable)
- Operating crystal frequency range:10MHz~27MHz
- Input signal frequency range:3MHz~27MHz
- 0.25~160MHz Output Frequency range
- Operating voltages: 1.62 V to 3.63V
- Operating temperature: -40°C to +125°C
- Configurable spread spectrum settings:
7 kinds of spread:
 $\pm 0.0625\%$, $\pm 0.125\%$, $\pm 0.25\%$, $\pm 0.5\%$, $\pm 1\%$, $\pm 1.5\%$, $\pm 2.0\%$
- OE disable function
- 3 kinds of Rise time/Fall time:
Default mode, Fast mode and Slow mode
- Modulation Frequency: $F_{IN}/804$
- Spread Profile: Triangle
- Used for Fundamental Crystal Oscillator
- Used for TDFN-8L package

Benefits

- Reduction in EMI
- System cost saving
- Reduced system complexity
- Faster time to market

Block Diagram

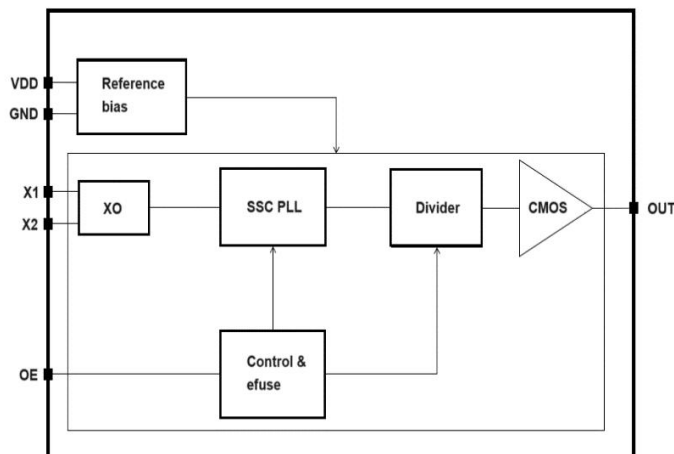

Description

The RS1XO6502ZAE is a versatile 1x Active EMI management IC designed to provide system wide reduction of Electromagnetic Interference (EMI) and Radio Frequency Interference (RFI) from clock and data sources. RS1XO6502ZAE allows significant system cost savings by reducing the number of circuit board layers, ferrite beads, shielding and other passive components that are traditionally required to pass EMI regulations.

This series offer the easy programmability of frequencies and other parameters, they also have a wider operating temperature range, from -40°C to +125°C. In addition to a 2×2.0 mm package that will enable electronics manufacturers to save board space. Users will be able to program the products to the required output frequency, as well as to the required spread spectrum settings.

This will also significantly contribute to performance, lower power requirements, fast development cycles, and low-volume production.

Applications

- IP Camera
- Printers/MFPs
- Media players
- DTV/Set-top Box
- Embedded digital video devices
- LCD Panel Modules
- Automotive components
- Networking devices
- Surveillance



Outline Drawing and Terminal Assignment

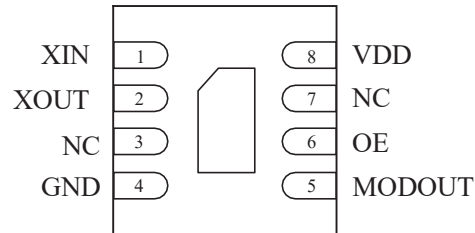

Pin#	Pin Name	Type	Description
1	XIN	I	Crystal Oscillator Input.
2	XOUT	O	Crystal Oscillator Output.
3	NC		No Connection
4	GND	P	System ground reference input.
5	MODOUT	O	phase modulated buffered output.
6	OE	O	Clock output if Pull-Up. Hi-Z Output if Pull-Down. Internal Pull-Up Resistor
7	NC		No Connection
8	VDD	P	System Power Supply pin.



Maximum Rating

Supply Voltage to Ground Potential.....	4V
OE pin	$V_{DD}+0.3V$
Storage Temperature.....	-40°C to +125°C

Note:
Stresses greater than those listed under MAXIMUM RATINGS may cause permanent damage to the device. This is a stress rating only and functional operation of the device at these or any other conditions above those indicated in the operational sections of this specification is not implied. Exposure to absolute maximum rating conditions for extended periods may affect reliability.

Recommended Operating Conditions

(GND=0V, unless otherwise noted.)

Sym.	Parameter	Conditions	Min	Typ	Max	Unit
V_{DD}	Supply voltage	-	1.62	-	3.63	V
V_{IN}	Input voltage	OE terminal	0	-	$V_{DD}+0.9$	V
T_A	Operating temperature	-	-40	25	+85	°C
			-40	25	+125	°C
L_{CMOS}	CMOS load condition	-	-	-	15	pf

Note:
* 0.1µF or over bypass capacitor should be connected between VCC and GND pins located close to the device

Frequency Characteristics

Sym.	Parameter	Conditions	Min	Typ	Max	Unit
F_O	Output frequency	OE terminal	0.25	-	160	MHz
F_{in}	Input Frequency	-	20	25	27	MHz

Note:
*1: Frequency tolerance includes initial frequency tolerance, frequency / temperature characteristics, frequency / voltage coefficient, frequency / load coefficient and frequency aging (+25 °C, first year)



DC Characteristics

V_{DD}= 1.62V to 3.63V, Ambient Temperature -40 to +125°C

Symbol	Parameter	Conditions	Min.	Typ.	Max.	Unit		
I _{DD}	Current consumption	V _{DD} =1.8V No load	2MHz		5.02		mA	
			10MHz	-	5.8		mA	
			25MHz	-	6.2		mA	
			50MHz	-	6.6		mA	
			100MHz	-	7.4		mA	
			160MHz	-	8.1		mA	
		V _{DD} =2.5V No load	2MHz			5.03		mA
			10MHz	-		6.4		mA
			25MHz	-		6.91		mA
			50MHz	-		7.4		mA
			100MHz	-		8.3		mA
			160MHz	-		9.3		mA
		V _{DD} =3.3V No load	2MHz			5.04		mA
			10MHz			6.6		mA
			25MHz			7.2		mA
			50MHz			7.8		mA
			100MHz			9.1		mA
			160MHz			10.4		mA
I _{DIS}	Disable current	V _{DD} =1.8V			5.9	mA		
		V _{DD} =2.5V			6.6	mA		
		V _{DD} =3.3V			6.7	mA		
I _{STD}	Standby current	V _{DD} =1.8V	-		1.0	mA		
		V _{DD} =2.5V	-		1.0	mA		
		V _{DD} =3.3V	-		1.0	mA		
V _{OH}	Output high voltage	V _{DD} =1.8V, I _{OH} = -2.5mA	0.9V _{DD}	-	-	V		
		V _{DD} =2.5V, I _{OH} = -4.0mA						
		V _{DD} =3.3V, I _{OH} = -5.0mA						
V _{OL}	Output low voltage	V _{DD} =1.8V, I _{OL} = 2.5mA	-	-	0.15V _{DD}	V		
		V _{DD} =2.5V, I _{OL} = 4.0mA						
		V _{DD} =3.3V, I _{OL} = 5.0mA						
V _{IH}	HIGH level input voltage	OE terminal	0.8V _{DD}	-		V		
V _{IL}	LOW level input voltage	OE terminal	-	-	0.2V _{DD}	V		
C _{IN}	Input pull-up resistance	OE terminal	-	2.5	5	pf		
R _{UP1}	Input pull-up resistance	OE= 80 % V _{DD}	20	-	150	kΩ		
R _{UP2}		OE= 20 % V _{DD}	5	-	60	MΩ		
R _{DN}	Output pull-down	OE= GND, OUT = V _{DD}	0.5		5	MΩ		



AC Characteristics

V_{DD}= 1.62V to 3.63V, Ambient Temperature -40 to +125°C

Symbol	Parameter	Conditions	Min.	Typ.	Max.	Unit	
T _{STR}	Start-up time	V _{DD} >1.62V	-	6	10	ms	
Duty cycle	Output duty cycle	Load=15pf, 50%V _{DD}	45	50	55	%	
Tr/Tf	Rise time/Fall time (20%V _{DD} ~80%V _{DD})	fo ≤ 20 MHz (Slow mode)			10	ns	
		fo ≤ 40 MHz (Default)			6	ns	
		fo > 40 MHz (Default)			3	ns	
		Fast mode			3	ns	
Tstp_OE	Output disable time (OE)	OE terminal HIGH → LOW			1	μs	
Tstp_ST	Output disable time (ST)	ST terminal HIGH → LOW			1	μs	
Tsta_OE	Output enable time (OE)	OE terminal LOW → HIGH			1	μs	
Tsta_ST	Output enable time (ST)	ST terminal LOW → HIGH			3	ms	
t _{c-c}	Cycle to Cycle jitter (Clock cycle > 50 000)	V _{DD} =1.8V load=15pf	10MHz			312.1	ps
			20MHz			225.3	ps
			50MHz			91.7	ps
			100MHz			70.4	ps
			160MHz			65.6	ps
		V _{DD} =2.5V load=15pf	10MHz			292.9	ps
			20MHz			136.6	ps
			50MHz			48.7	ps
			100MHz			37.6	ps
			160MHz			40	ps
		V _{DD} =3.3V load=15pf	10MHz			290.1	ps
			20MHz			128.8	ps
			50MHz			44.6	ps
			100MHz			31.3	ps
			160MHz			29.5	ps
fmod	Modulation frequency			F _{in} /804		KHz	

Note: Typical condition is on room temperature at 25°



Timing Chart

(1) Output Waveform and Level

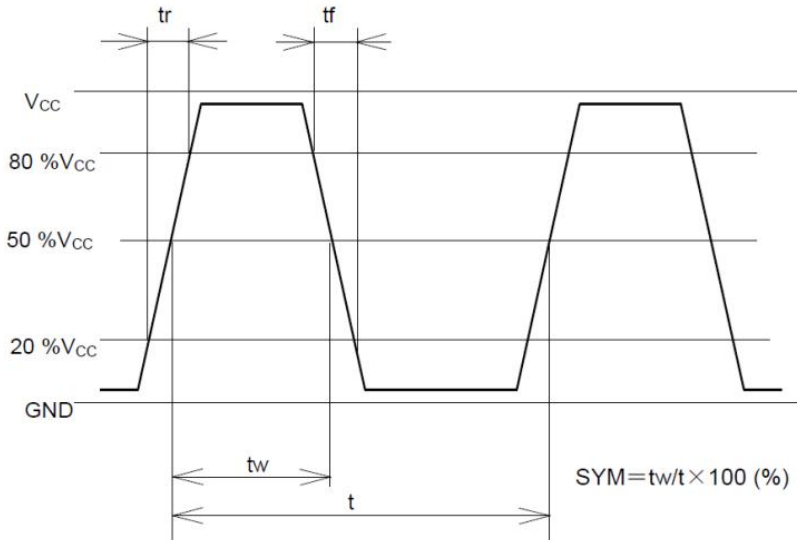

(2) OE/ \overline{ST} Function and Timing

OE/ \overline{ST} terminal	Osc. circuit	Output status
"H"	Oscillation	Specified frequency: Enable
"L"	OE: Oscillation	Low (Weak pull down*3): Disable
	\overline{ST} : Oscillation stop	

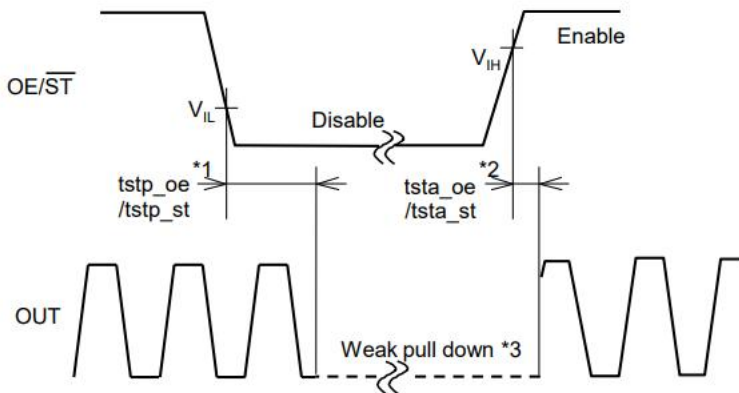

*1 The period from OE/ \overline{ST} = V_{IL} to OUT = Low (weak pull down) (Disable)

*2 The period from OE/ \overline{ST} = V_{IH} to OUT = Enable

*3 Pulled down with Output pull down resistance (R_{DN})

* Judging the start of output when output waveform is observed.

* OE/ \overline{ST} terminal voltage level should not exceed supply voltage when using OE/ \overline{ST} function.

Please note that OE/ \overline{ST} rise time should not exceed supply voltage rise time at the start-up.

* Please do not use the OE/ \overline{ST} terminal in the open state.

Typically the output will be enable when OE/ \overline{ST} is open state, but the input pull resistance is large and OE/ \overline{ST} terminal may drop to "L" level and be disable due to noise or leakage current.



3) Triangle

Center spread, spread width: $\pm 0.5\%$

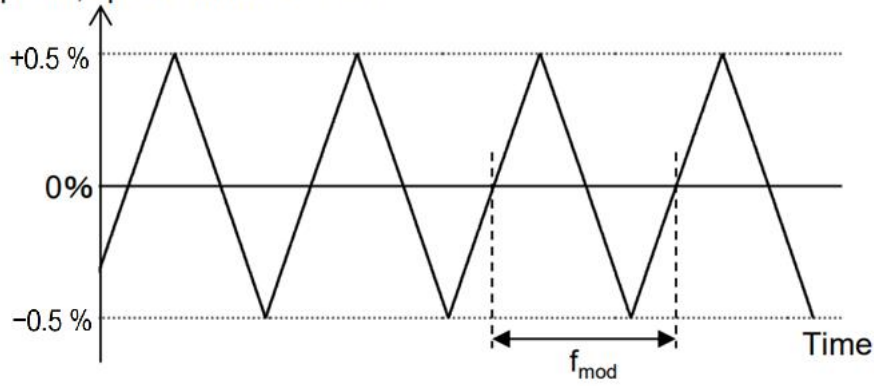

Application Circuit

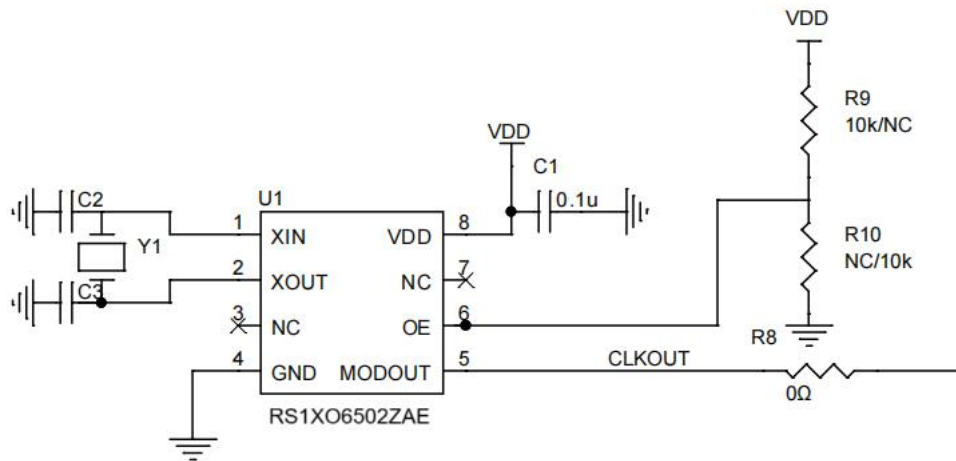



Package Dimension

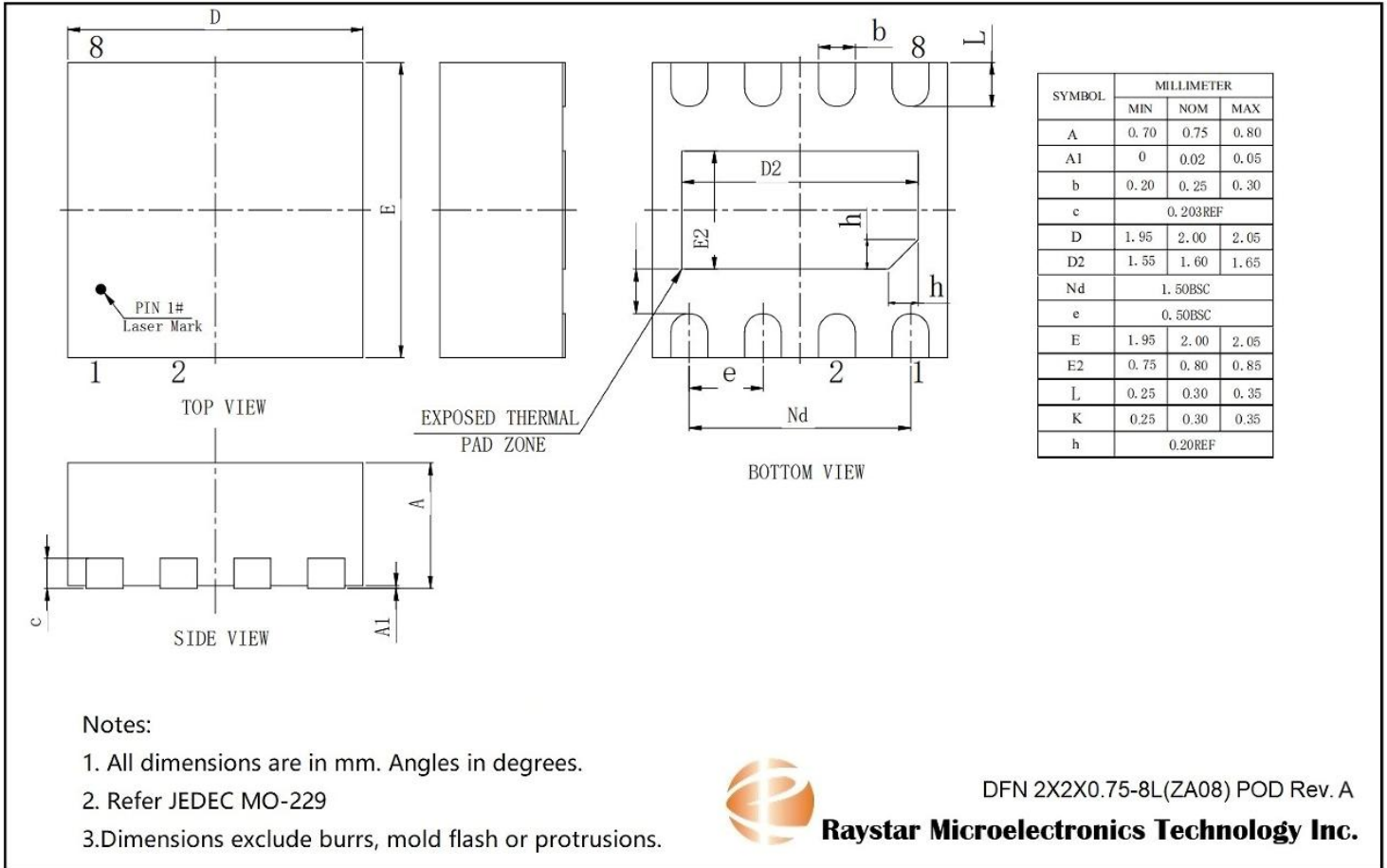

Revision History

Revision	Description	Date
0.9	Preliminary Datasheet Initiated	2025/2/25
1.0	Initial release	2025/5/7
1.1	Update Order Information, Update Features	2026/4/29
1.2	Update Start-up time	2026/6/26