



Features

- No Direction-Control
- Max Data Rates
24Mbps (Push-Pull)
2Mbps (Open-Drain)
- 1.2V to 3.63V on A ports and 1.2V to 3.63V on B Ports
- VCCA can be Less than, Greater than or Equal to VCCB
- VCC Isolation: If Either VCC is at GND, Both Ports are in the High-Impedance State
- No Power-Supply Sequencing Required: VCCA or VCCB can be Ramped First
- ESD protection exceeds 6000V HBM, 1000V CDM
- AEC-Q100 qualified, PPAP capable, and manufactured in IATF 16949 certified facilities.
- Grade 1 temperature range (- 40°C ~ +125 °C)

Applications

- I2C/SMBus
- SPI Interface
- UART
- Handheld Devices Interface

Description

The RS7LS104Q is a 4-bit configurable dual supply bidirectional auto sensing translator that does not require a directional control pin. The A and B ports are designed to track two different power supply rails, VCCA and VCCB respectively.

A port supporting operating voltages from 1.2V to 3.63V while it tracks the VCCA supply, and the B ports supporting operating voltages from 1.2V to 3.63V while it tracks the VCCB supply. This allows the support of both lower and higher logic signal levels while providing bidirectional translation capabilities between any of the 1.2V, 1.8V, 2.5V, 3.3V voltage and 3.63V nodes.

When the output-enable (EN) input is low, all outputs are placed in the high-impedance state. To ensure the high-impedance state during power up or power down, EN should be tied to GND through a pulldown resistor; the minimum value of the resistor is determined by the current-sourcing capability of the driver.

Ordering Information

Ordering Code	Package	Description
RS7LS104QZME	ZM	UQFN-12, 1.7mmx2.0 mm
RS7LS104QLE	L	TSSOP-14, pitch 0.65mm
RS7LS104QZBE	ZB	TQFN-14, 3.5mmX3.5mm

Notes:

E = Pb-free and Green



Block Diagram

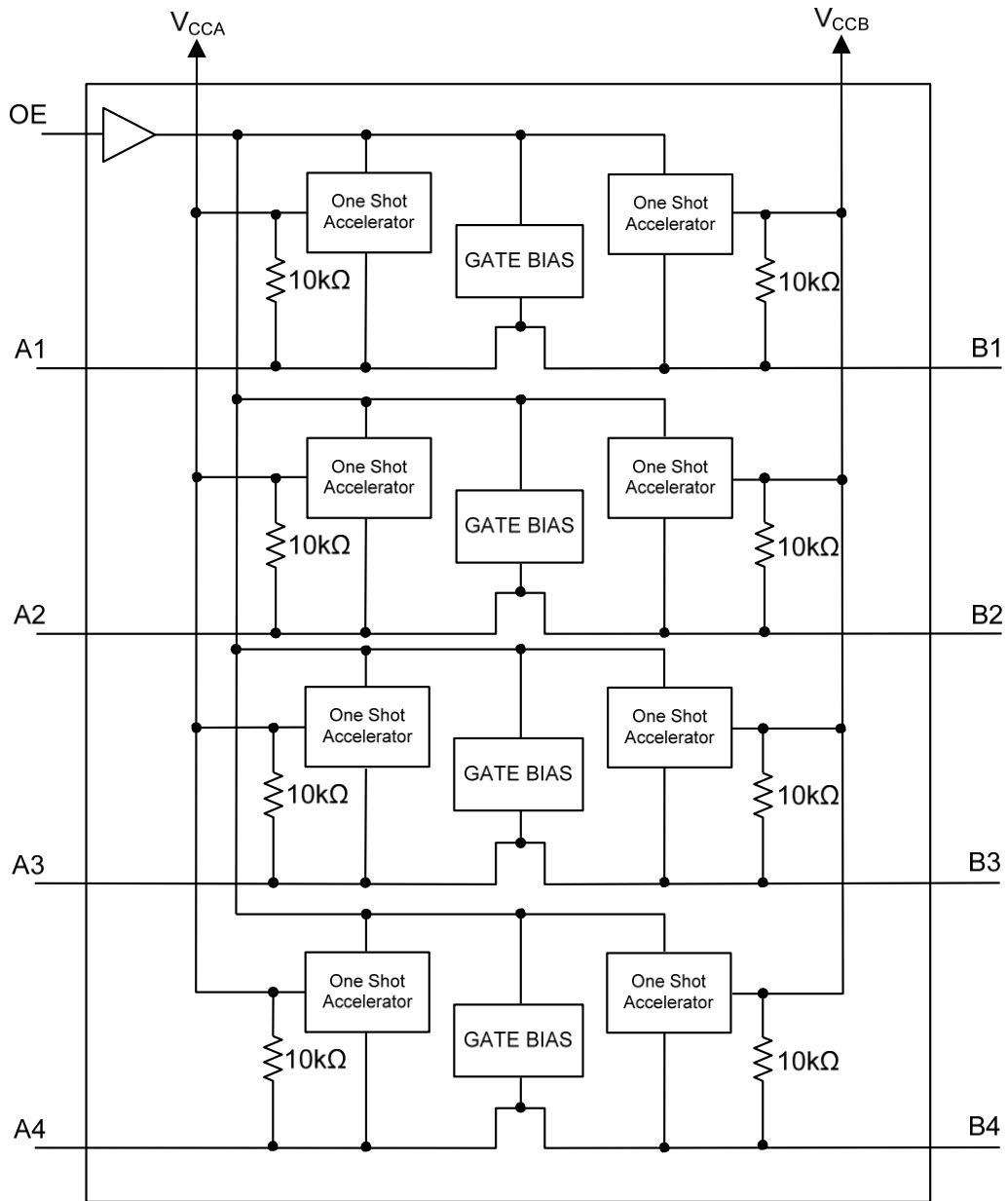
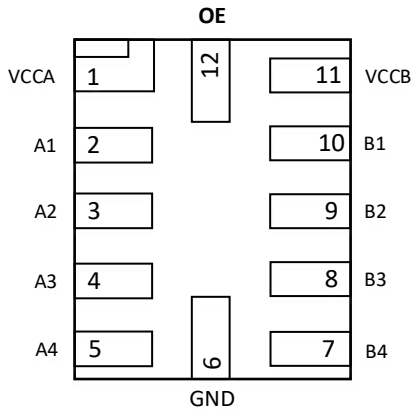

Figure 1 Block Diagram



Pin Configuration

UQFN-12(Top View)



TSSOP-14(Top View)

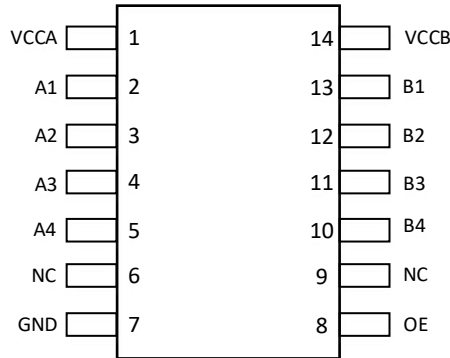

TQFN-14(Top View)

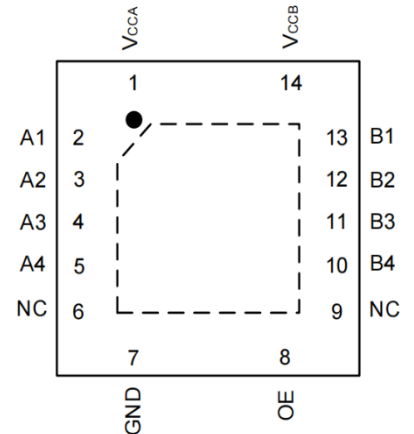

Figure 2 Pin Configuration

Pin Name	UQFN-12	TSSOP-14	TQFN-14	Description
VCCA	1	1	1	A-port supply voltage. $1.2V \leq VCCA \leq 3.63V$
A1	2	2	2	Input/output A. Referenced to VCCA.
A2	3	3	3	Input/output A. Referenced to VCCA
A3	4	4	4	Input/output A. Referenced to VCCA
A4	5	5	5	Input/output A. Referenced to VCCA
GND	6	7	7	Ground.
OE	12	8	8	Output enables (active High). Pull OE low to place all outputs in 3-state mode.
B4	7	10	10	Input/output B. Referenced to VCCB
B3	8	11	11	Input/output B. Referenced to VCCB
B2	9	12	12	Input/output B. Referenced to VCCB
B1	10	13	13	Input/output B. Referenced to VCCB
VCCB	11	14	14	B-port supply voltage. $1.2V \leq VCCB \leq 3.63V$
NC	/	6,9	6,9	Not Connect



Absolute Maximum Ratings

Symbol	Parameter	MIN	TYP	MAX	Unit
Tstore	Storage Temperature	-65	-	150	°C
VCCA	DC Supply Voltage port B	-0.3	-	5.5	V
VCCB	DC Supply Voltage port A	-0.3	-	5.5	V
VIOB	Vi(A) referenced DC Input / Output Voltage	-0.3	-	5.5	V
VIOB	Vi(B) referenced DC Input / Output Voltage	-0.3	-	5.5	V
VEN	Enable Control Pin DC Input Voltage	-0.3	-	5.5	V
Ishort	Short circuit duration (I/O to GND)			50	mA

Notes:

Stresses greater than those listed under MAXIMUM RATINGS may cause permanent damage to the device. This is a stress rating only and functional operation of the device at these or any other conditions above those indicated in the operational sections of this specification is not implied. Exposure to absolute maximum rating conditions for extended periods may affect reliability.

Recommended operation conditions

Symbol	Parameter	MIN	TYP	MAX	Unit
VCCA	VCCA Positive DC Supply Voltage	1.2	-	3.63	V
VCCB	VCCB Positive DC Supply Voltage	1.2	-	3.63	V
VEN	Enable Control Pin Voltage	GND	-	3.63	V
VIO	I/O Pin Voltage	GND	-	3.63	V
$\Delta t / \Delta V$	Input transition rise or fall time	-	-	10	ns/V
TA	Operating Temperature Range	-40	-	125	°C



DC Electrical Characteristics

Unless otherwise specified, $-40^{\circ}\text{C} \leq T_A \leq 125^{\circ}\text{C}$, $1.2\text{V} \leq V_{\text{CCA}} \leq 3.63\text{V}$, $1.2\text{V} \leq V_{\text{CCB}} \leq 3.63\text{V}$

Symbol	Parameter	Test Conditions*1	MIN	TYP	MAX	Unit	
VIHA	A port Input HIGH Voltage	$2.3\text{V} \leq V_{\text{CCA}} \leq 3.63\text{V}$	$V_{\text{CCA}} - 0.4$			V	
		$1.2\text{V} \leq V_{\text{CCA}} < 2.3\text{V}$	$V_{\text{CCA}} - 0.2$			V	
VILA	A port Input LOW Voltage	$1.2\text{V} \leq V_{\text{CCA}} \leq 3.63\text{V}$	-	-	0.15	V	
VIHB	B port Input HIGH Voltage	$2.3\text{V} \leq V_{\text{CCB}} \leq 3.63\text{V}$	$V_{\text{CCB}} - 0.4$	-	-	V	
		$1.2\text{V} \leq V_{\text{CCB}} < 2.3\text{V}$	$V_{\text{CCB}} - 0.2$				
VILB	B port Input LOW Voltage	$1.2\text{V} \leq V_{\text{CCB}} \leq 3.63\text{V}$	-	-	0.15	V	
VIH(EN)	Control Pin Input HIGH Voltage	$1.2\text{V} \leq V_{\text{CCA}} \leq 3.63\text{V}$	$0.65 \cdot V_{\text{CCA}}$	-	-	V	
VIL(EN)	Control Pin Input LOW Voltage	$1.65\text{V} \leq V_{\text{CCA}} \leq 3.63\text{V}$	-	-	$0.35 \cdot V_{\text{CCA}}$		
		$1.2\text{V} \leq V_{\text{CCA}} < 1.65\text{V}$			0.15	V	
VOHA	A port Output HIGH Voltage	A port source current = $-20\ \mu\text{A}$	$0.8 \cdot V_{\text{CCA}}$	-	-	V	
VOLA	A port Output LOW Voltage	A port sink current = $1\ \text{mA}$	-	-	0.4	V	
VOHB	B port Output HIGH Voltage	B port source current = $-20\ \mu\text{A}$	$0.8 \cdot V_{\text{CCB}}$	-	-	V	
VOLB	B port Output LOW Voltage	B port sink current = $1\ \text{mA}$	-	-	0.4	V	
ICCA	VCCA Supply Current	OE=High	$V_{\text{CCA}}=1.2\text{V to } 3.63\text{V},$ $V_{\text{CCB}}=1.2\text{V to } 3.63\text{V}$	-	0.2	2.4	μA
			$V_{\text{CCA}}= 3.63\text{V}, V_{\text{CCB}}= 0\text{V}$	-	-	2	μA
			$V_{\text{CCA}}= 0\text{V}, V_{\text{CCB}}=3.63\text{V}$	-	-	1	μA
ICCB	VCCB Supply Current	OE=High	$V_{\text{CCA}}=1.2\text{V to } 3.63\text{V},$ $V_{\text{CCB}}=1.2\text{V to } 3.63\text{V}$	-	0.5	10	μA
			$V_{\text{CCA}}= 3.63\text{V}, V_{\text{CCB}}= 0\text{V}$	-	-	1	μA
			$V_{\text{CCA}}= 0\text{V}, V_{\text{CCB}}=3.63\text{V}$	-	-	8	μA
ICCA +ICCB	Combined supply current	OE=High	$V_{\text{CCA}}=1.2\text{V to } 3.63\text{V},$ $V_{\text{CCB}}=1.2\text{V to } 3.63\text{V}$			15	μA
ICCZA	Static supply current VCCA	OE=Low	$V_{\text{CCA}}=1.2\text{V to } 3.63\text{V},$ $V_{\text{CCB}}=1.2\text{V to } 3.63\text{V}$			8	μA
ICCZB	Static supply current VCCB					8	μA
IOZ	I/O Tri-state Output Mode Leakage Current	A or B	$V_{\text{IA}}=0-V_{\text{CCA}}$			± 8	μA
		Port	$V_{\text{IB}}=0-V_{\text{CCB}}$				
IOFF	Partial power down current	A port	$V_{\text{CCA}}=0\text{V}, V_{\text{CCB}}=1.2\text{V to } 3.63\text{V}$			± 8	μA
		B port	$V_{\text{CCA}}=1.2\text{V to } 3.63\text{V}$ $V_{\text{CCB}}=0\text{V}$			± 8	μA
II-EN	Control pin leakage Current	$V_{\text{I}} = V_{\text{CCI}}$ or GND	-	-	± 2	μA	
RPU	Pull-Up Resistors I/O A and B	-	-	10	-	$\text{k}\Omega$	
Ci	EN	$V_{\text{CCA}}= 3.3\text{V}, V_{\text{CCB}}= 3.3\text{V}$	-	-	1	pF	
CIO	A port	$V_{\text{CCA}}= 3.3\text{V}, V_{\text{CCB}}= 3.3\text{V}$	-	-	5	pF	
	B port	$V_{\text{CCA}}= 3.3\text{V}, V_{\text{CCB}}= 3.3\text{V}$	-	-	5	pF	

Note:

- All units are production tested at $T_A = +25^{\circ}\text{C}$. Limits over the operating temperature range are guaranteed by design. Typical values are for $V_{\text{CCB}} = +3.3\text{V}$, $V_{\text{CCA}} = +1.8\text{V}$ and $T_A = +25^{\circ}\text{C}$.



AC Electrical characteristics

$C_{LOAD} = 15\text{pF}$, driver output impedance $\leq 50\Omega$, $R_{LOAD} = 1\text{M}\Omega$, $T_A = -40^\circ\text{C}$ to 125°C ,

VCCA= 1.2V

Over recommended operating free-air temperature range (unless otherwise noted)

Symbol	Parameter	Test Conditions	VCCB=1.8V		VCCB=2.5V		VCCB=3.3V		Unit
			MIN	MAX	MIN	MAX	MIN	MAX	
t_{PHL_AB}	Propagation Delay A \rightarrow B	Push-pull		12		10		10	ns
		Open-drain		30		30		30	ns
t_{PLH_AB}	Propagation Delay A \rightarrow B	Push-pull		20		15		15	ns
		Open-drain		30		30		30	ns
t_{PHL_BA}	Propagation Delay B \rightarrow A	Push-pull		12		10		10	ns
		Open-drain		30		30		30	ns
t_{PLH_BA}	Propagation Delay B \rightarrow A	Push-pull		20		15		15	ns
		Open-drain		50		50		50	ns
t_{EN}	Enable Time	EN to A or B		380		200		200	ns
t_{DIS}	Disable Time	EN to A or B		200		200		200	ns
t_{RA}	A port Rise Time	Push-pull		30		30		30	ns
		Open-drain		160		120		120	ns
t_{RB}	B port Rise Time	Push-pull		30		30		30	ns
		Open-drain		160		160		160	ns
t_{FA}	A port Fall Time	Push-pull		20		20		25	ns
		Open-drain		30		30		30	ns
t_{FB}	B port Fall Time	Push-pull		20		20		25	ns
		Open-drain		30		30		30	ns
t_{SKEW}	Channel to Channel Skew			1		1		1	ns
MDR	Maximum Data Rate	Push-pull	20		20		20		Mbps
		Open-drain	2		2		2		Mbps



VCCA= 1.8V

Over recommended operating free-air temperature range (unless otherwise noted)

Symbol	Parameter	Test Conditions	VCCB=1.2V		VCCB=2.5V		VCCB = 3.3V		Unit
			MIN	MAX	MIN	MAX	MIN	MAX	
t _{PHL_AB}	Propagation Delay A → B	Push-pull		12		10		9	ns
		Open-drain		30		30		30	ns
t _{PLH_AB}	Propagation Delay A → B	Push-pull		20		12		11	ns
		Open-drain		30		30		30	ns
t _{PHL_BA}	Propagation Delay B → A	Push-pull		12		9		9	ns
		Open-drain		30		30		30	ns
t _{PLH_BA}	Propagation Delay B → A	Push-pull		20		14		12	ns
		Open-drain		50		50		50	ns
t _{EN}	Enable Time	EN to A or B		200		200		200	ns
t _{DIS}	Disable Time	EN to A or B		200		200		200	ns
t _{RA}	A port Rise Time	Push-pull		30		30		30	ns
		Open-drain		160		120		120	ns
t _{RB}	B port Rise Time	Push-pull		30		30		30	ns
		Open-drain		160		160		160	ns
t _{FA}	A port Fall Time	Push-pull		20		20		25	ns
		Open-drain		30		30		30	ns
t _{FB}	B port Fall Time	Push-pull		20		25		30	ns
		Open-drain		30		30		30	ns
t _{SKREW}	Channel to Channel Skew			1		1		1	ns
MDR	Maximum Data Rate	Push-pull	20		20		24		Mbps
		Open-drain	2		2		2		Mbps



V_{CCA} = 2.5V

Over recommended operating free-air temperature range (unless otherwise noted)

Symbol	Parameter	Test Conditions	VCCB= 1.2V		VCCB= 1.8V		VCCB = 3.3V		Unit
			MIN	MAX	MIN	MAX	MIN	MAX	
t _{PHL_AB}	Propagation Delay A → B	Push-pull		10		9		9	ns
		Open-drain		30		30		30	ns
t _{PLH_AB}	Propagation Delay A → B	Push-pull		15		12		10	ns
		Open-drain		30		30		30	ns
t _{PHL_BA}	Propagation Delay B → A	Push-pull		10		10		9	ns
		Open-drain		30		30		30	ns
t _{PLH_BA}	Propagation Delay B → A	Push-pull		15		12		12	ns
		Open-drain		50		50		50	ns
t _{EN}	Enable Time	EN to A or B		200		200		200	ns
t _{DIS}	Disable Time	EN to A or B		200		200		200	ns
t _{RA}	A port Rise Time	Push-pull		30		30		30	ns
		Open-drain		160		120		120	ns
t _{RB}	B port Rise Time	Push-pull		30		30		30	ns
		Open-drain		160		160		160	ns
t _{FA}	A port Fall Time	Push-pull		20		25		30	ns
		Open-drain		30		30		30	ns
t _{FB}	B port Fall Time	Push-pull		20		20		25	ns
		Open-drain		30		30		30	ns
t _{SKEW}	Channel to Channel Skew			1		1		1	ns
MDR	Maximum Data Rate	Push-pull	20		20		24		Mbps
		Open-drain	2		2		2		Mbps



V_{CCA} = 3.3V

Over recommended operating free-air temperature range (unless otherwise noted)

Symbol	Parameter	Test Conditions	V _{CCB} = 1.2V		V _{CCB} = 1.8V		V _{CCB} = 2.5V		Unit
			MIN	MAX	MIN	MAX	MIN	MAX	
t _{PHL_AB}	Propagation Delay A → B	Push-pull		10		9		9	ns
		Open-drain		30		30		30	ns
t _{PLH_AB}	Propagation Delay A → B	Push-pull		15		12		12	ns
		Open-drain		30		30		30	ns
t _{PHL_BA}	Propagation Delay B → A	Push-pull		10		9		9	ns
		Open-drain		30		30		30	ns
t _{PLH_BA}	Propagation Delay B → A	Push-pull		15		11		10	ns
		Open-drain		50		50		50	ns
t _{EN}	Enable Time	EN to A or B		200		200		200	ns
t _{DIS}	Disable Time	EN to A or B		200		200		200	ns
t _{RA}	A port Rise Time	Push-pull		30		30		30	ns
		Open-drain		160		120		120	ns
t _{RB}	B port Rise Time	Push-pull		30		30		30	ns
		Open-drain		160		160		160	ns
t _{FA}	A port Fall Time	Push-pull		25		25		25	ns
		Open-drain		30		30		30	ns
t _{FB}	B port Fall Time	Push-pull		25		25		25	ns
		Open-drain		30		30		30	ns
t _{SKEW}	Channel to Channel Skew			1		1		1	ns
MDR	Maximum Data Rate	Push-pull	20		24		24		Mbps
		Open-drain	2		2		2		Mbps



Parameter Measurement Information

Load Circuits

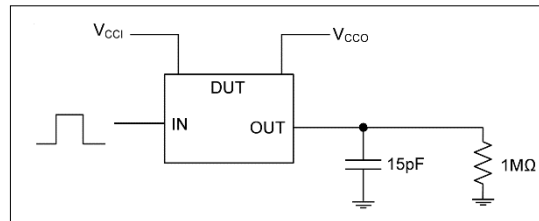

Figure 3 Data Rate, Pulse Duration, Propagation Delay, Output Rise-Time and Fall-Time Measurement Using a Push-Pull Driver

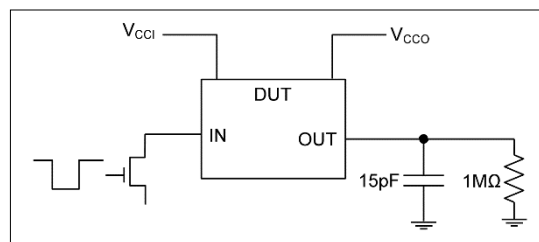
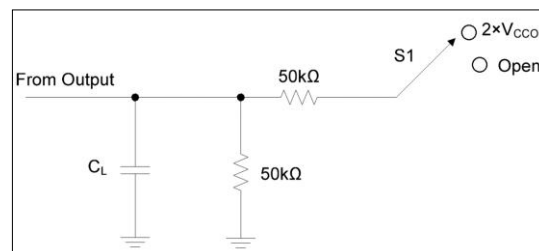

Figure 4 Data Rate, Pulse Duration, Propagation Delay, Output Rise-Time and Fall-Time Measurement Using an Open-Drain Driver



TEST	S1
tPZL / tPLZ	2 × VCCO
tPHZ / TpzH	Open

Figure 5 Load Circuit for Enable-Time and Disable-Time Measurement

Notes:

1. CL includes probe and jig capacitance.
2. ten is the same as tPZL and tPZH. tdis is the same as tPLZ and tPHZ.
3. VccI is the supply voltage associated with the input.
4. Vcco is the supply voltage associated with the output.



Voltage Waveforms

The outputs are measured one at a time, with one transition per measurement. All input pulses are supplied by generators that have the following characteristics:

- $PRR \leq 10 \text{ MHz}$
- $Z_O = 50 \ \Omega$
- $dv/dt \geq 1 \text{ V/ns}$

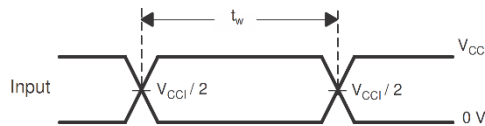

Figure 6 Pulse Duration

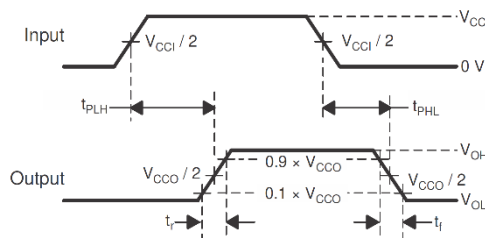
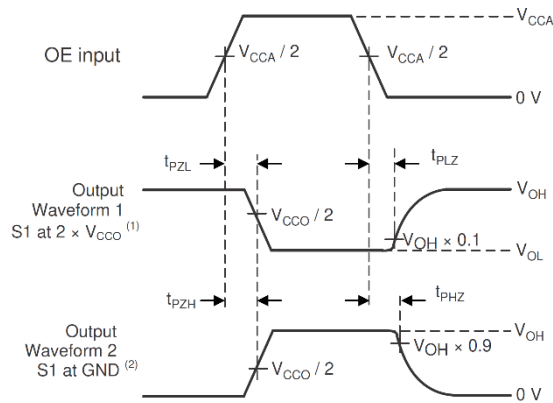

Figure 7 Propagation Delay Times



- A. Waveform 1 is for an output with internal such that the output is high, except when OE is high.
B. Waveform 2 is for an output with conditions such that the output is low, except when OE is high.

Figure 8 Enable and Disable Times



Functional Description

Architecture

The RS7LS104Q architecture does not require a direction-control signal in order to control the direction of data flow from A to B or from B to A.

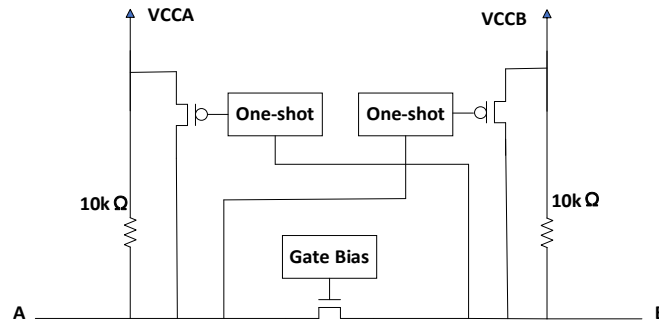

Figure 9 Level Shifter Architecture

Each A-port I/O has an internal 10kΩ pull up resistor to V_{CCA} , and each B-port I/O has an internal 10kΩ pull-up resistor to V_{CCB} . The output one-shots detect rising edges on the A or B ports. During a rising edge, the one-shot turns on the PMOS transistors for a short duration, which speeds up the low-to-high transition.

Input Driver Requirements

The rise (t_R) and fall (t_F) timing parameters of the open drain outputs depend on the magnitude of the pull-up resistors. In addition, the propagation times (t_{PD}), skew (t_{SKEW}) and maximum data rate depend on the impedance of the device that is connected to the translator. The timing parameters listed in the data sheet assume that the output impedance of the drivers connected to the translator is less than 50 kΩ .

Enable Input (OE)

The RS7LS104Q has an Enable pin (OE) that provides tri-state operation at the I/O pins. Driving the Enable pin to a low logic level minimizes the power consumption of the device and drives the I/O V_{CCB} and I/O V_{CCA} pins to a high impedance state. Normal translation operation occurs when the OE pin is equal to a logic high signal. The OE pin is referenced to the V_{CCA} supply and has overvoltage tolerant protection.

Pull-up or Pull-down Resistors on I/O Lines

Each A-port I/O has an internal 10kΩ pull-up resistor to V_{CCA} , and each B-port I/O has an internal 10 kΩ pull-up resistor to V_{CCB} . If a smaller value of pull-up resistor is required, an external resistor must be added from the I/O to V_{CCA} or V_{CCB} (in parallel with the internal 10 kΩ resistors).

Device Functional Modes

The RS7LS104Q device has two functional modes, enabled and disabled. To disable the device set the OE input low, which places all I/Os in a high impedance state. Setting the OE input high will enable the device.



Application Information

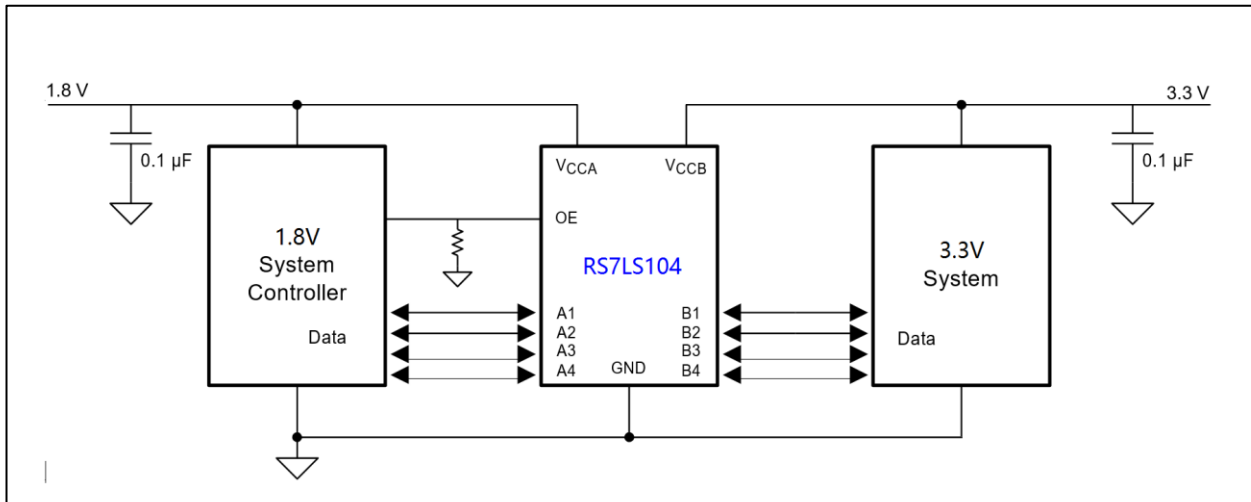

Figure 10 Application Circuit

Power Supply Guidelines

During normal operation, supply voltage V_{CCA} can be greater than, less than or equal to V_{CCB} . The sequencing of the power supplies will not damage the device during the power up operation. For optimal performance, $0.01\mu\text{F}$ to $0.1\mu\text{F}$ decoupling capacitors should be used on the V_{CCA} and V_{CCB} power supply pins. Ceramic capacitors are a good design choice to filter and bypass any noise signals on the voltage lines to the ground plane of the PCB. The noise immunity will be maximized by placing the capacitors as close as possible to the supply and ground pins, along with minimizing the PCB connection traces.



Package Information

UQFN 1.7x2.0-12L

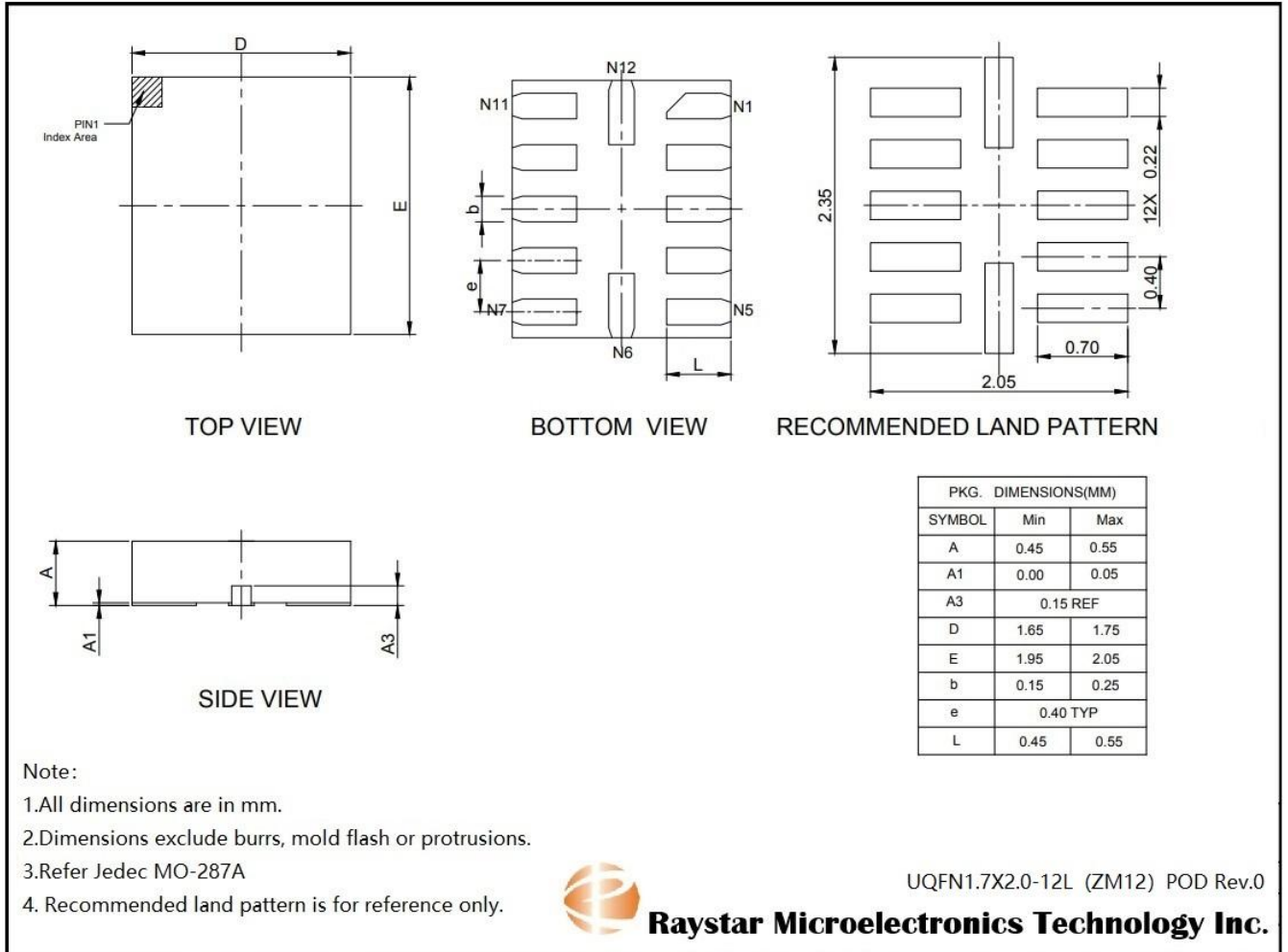



TSSOP-14L

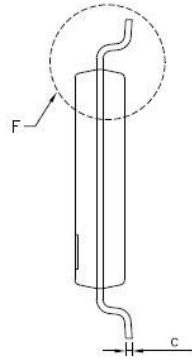
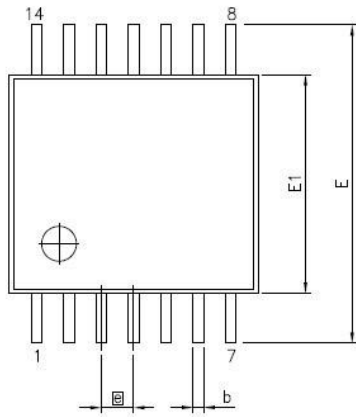

SYMBOLS	MIN.	NOM.	MAX.
A	—	—	1.20
A1	0.05	—	0.15
A2	0.80	1.00	1.05
b	0.19	—	0.30
c	0.09	—	0.20
D	4.90	5.00	5.10
E1	4.20	4.35	4.50
E	6.20	6.40	6.60
\square e	0.65 BSC		
L1	1.00 REF		
L	0.45	0.60	0.75
S	0.20	—	—
θ	0°	—	8°

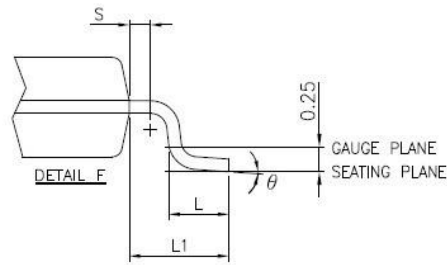
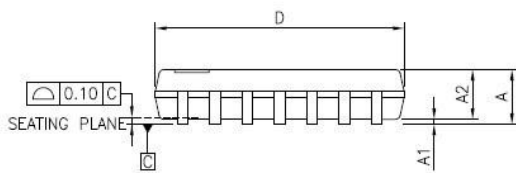

Note:

1. All dimensions are in mm. Angles in degrees.
2. Dimensions exclude burrs, mold flash or protrusions.
3. Refer Jeduc MO-153F
4. Recommended land pattern is for reference only.





TQFN3.5X3.5-14L

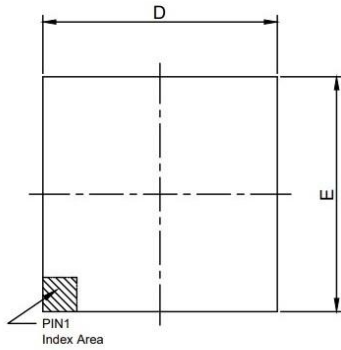

TOP VIEW

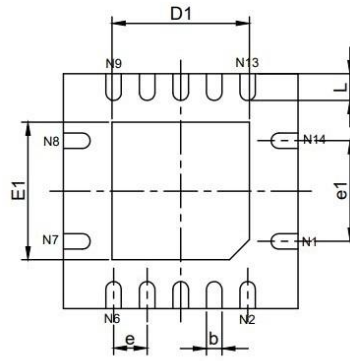

BOTTOM VIEW

PKG. DIMENSIONS(MM)		
SYMBOL	Min	Max
A	0.70	0.80
A1	0.00	0.05
A3	0.20 REF	
D	3.42	3.58
E	3.42	3.58
D1	1.95	2.15
E1	1.95	2.15
b	0.20	0.30
e	0.50 TYP	
e1	1.50 TYP	
L	0.32	0.48

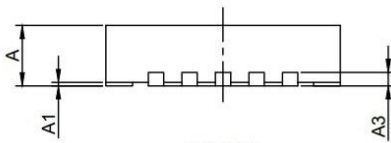

SIDE VIEW

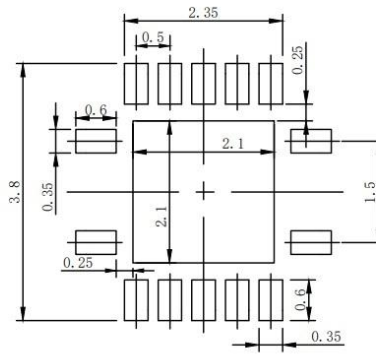

RECOMMENDED LAND PATTERN(unit:mm)

Note:

- 1.All dimensions are in mm.
- 2.Dimensions exclude burrs, mold flash or protrusions.
- 3.Refer Jedec MO-220
4. Recommended land pattern is for reference only.





Revision History

Revision	Description	DATE
1.0	Initial Release	2024/5/28
1.1	ADD TQFN-14 package and ordering information	2024/9/14
1.2	Update TSSOP14 package information	2026/5/12