



XO5009ALx-C Series High Performance Fundamental Crystal Oscillator IC

Features

- Wide range of operating supply voltage: 2.2V to 5.5V
- Optimized low crystal drive current oscillation for miniature crystal units
- XO5009ALx-C series: for Wire Bonding
- Recommended oscillation frequency range
- Low frequency Fundamental: 10MHz to 60MHz
- Multi-stage frequency divider for low-frequency output support
- **High Performance(Low Phase Noise/Low Jitter)**
- **High Frequency VS Vdd Stability <+/-1ppm**
- **Ultra-Low Drive Level**
- **Ultra-low Power Current**
- Frequency divider built-in:
-Selectable by version: f0, f0/2, f0/4, f0/8
- **-55 to 125 °C operating temperature range**
- **50pF output drive capability**
- Standby function
- High impedance in standby mode, oscillator stops
- CMOS output duty level(1/2VDD)
-50 ± 5% output duty
- Die form or Wafer form

Description

The XO5009ALx-C series are miniature crystal oscillator module ICs. The oscillator circuit stage has voltage regulator drive, significantly reducing current consumption and crystal current, compared with existing devices, and significantly reducing the oscillator characteristics supply voltage dependency.

Application

- Used for crystal oscillator
- 7050, 5032 Crystal Oscillator
- 3225, 2520, Crystal Oscillator

Ordering Information

Part no.	Package type
XO5009ALx-C-zWF	Wafer form
XO5009ALx-C-zDE	Die form

Note: 1. Below is the detailed definition of part no.

Note: 2. xx:3/4, z: -3(130um), -4(100um)

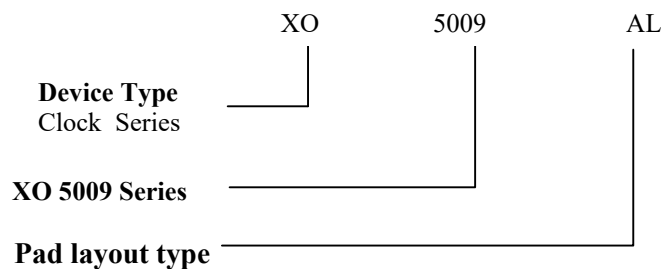

Suffix	f _{output}	Frequency range
1	f ₀	10 to 50MHz
2	f ₀ /2	
3	f ₀ /4	
4	f ₀ /8	
5	f ₀ /16	
6	f ₀ /32	
7	f ₀ /64	

X: 3 Stand for 130um die thickness
4 Stand for 100um die thickness



Series Configuration

Part No.	Output frequency	Operating supply voltage range(V)	Oscillation mode	Recommended oscillation frequency range ^{*1} (MHz)	Output drive capability(mA)	Standby mode	
						Oscillator stop function	Output state
XO5009AL1-C	f0	2.2~5.5	Fundamental	10 to 50	16	Yes	Hi-Z
XO5009AL2-C	f0/2						
XO5009AL3-C	f0/4						
XO5009AL4-C	f0/8						
XO5009AL5*2	f0/16						
XO5009AL6*2	f0/32						
XO5009AL7*2	f0/64						

Block Diagram

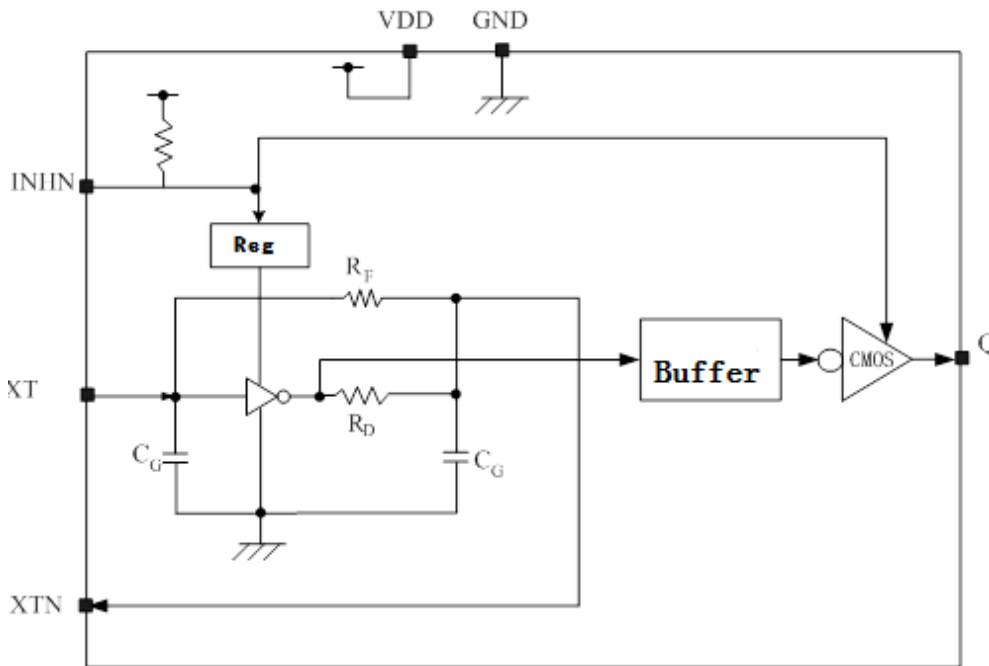



Function Description

Standby Function

When INHN goes LOW, the oscillator stops and the output on Q becomes high impedance.

INHN	Q	Oscillator
HIGH (or open)	fo output frequency	Normal operation
Low	High impedance	Stopped

Power-saving Pull-up Resistor

The INHN pin pull-up resistance RUP1 or RUP2 changes in response to the input level(HIGH or LOW). When INHN is tied LOW level, the pull-up resistance is large(RUP1),reducing the current consumed by the resistance. When INHN is left open circuit, the pull-up resistance is small(RUP2),which increases the input susceptibility to external noise. However, the pull-up resistance ties the INHN pin HIGH level to prevent external noise from unexpectedly stopping the output.

Oscillation Detector Function

The XO5009ALx-C series also feature an oscillation detector circuit. This circuit functions make the outputs disable until the oscillator circuit starts and oscillation becomes stable. This alleviates the danger of abnormal oscillator output at oscillator start-up when power is applied or when INHN is switched



Maximum Ratings

Storage Temperature.....	-65°C to +150°C
Supply Voltage to Ground Potential (V _{DD} to GND).....	-0.5V to +7.0V
DC Input (All Other Inputs except V _{DD} & GND) ...	-0.5V to V _{DD} +0.5V
DC Output.....	-0.5V to V _{DD} +0.5V
DC Output Current (all outputs)	20mA

Note:

Stresses greater than those listed under MAXIMUM RATINGS may cause permanent damage to the device. This is a stress rating only and functional operation of the device at these or any other conditions above those indicated in the operational sections of this specification is not implied. Exposure to absolute maximum rating conditions for extended periods may affect reliability.

Recommended Operating Conditions

(GND=0V, unless otherwise noted.)

Sym.	Parameter	Series	Conditions	Min	Typ	Max	Unit
V _{DD}	Supply voltage	All series	C _L = 15pF	2.2	-	5.5	V
V _{IN}	Input voltage	All series	-	GND	-	V _{DD}	V
T _A	Operating temperature	All series	-	-55	-	+125	°C
f ₀	Oscillation frequency*1	5009x1-5009x4	V _{DD} =2.2V~5.5V -	10	-	50	MHz
f _{OUT}	Output frequency	5009x1-5009x4	V _{DD} =2.2V~5.5V		-	50	MHz

Reliability Data

Sym.	Parameter	Series	Conditions	Min	Typ	Max	Unit
ESD	Human Body Model	All series	MIL-STD-883H Method 3015.8	+/-3000	+/-7500		V

Note: Industrial Standard ESD: HBM Model +/-2000V



DC Electrical Characteristics

XO5009AL1-C to XO5009AL6-C ($V_{DD} = 2.5$ to $5.5V$, $T_A = -40$ to $85^{\circ}C$, unless otherwise noted.)

Sym.	Parameter	Condition	Rating			Unit		
			min	typ	max			
V_{OH}	HIGH-level output voltage	Q: Measurement cct3, $I_{OH}=8mA$	$V_{DD}-0.4$	-	-	V		
V_{OL}	LOW-level output voltage	Q: Measurement cct3, $I_{OL}=8mA$	-	-	0.4	V		
V_{IH}	HIGH-level input voltage	INH, Measurement cct4	$0.7V_{DD}$	-	-	V		
V_{IL}	LOW-level input voltage	INH, Measurement cct4	-	-	$0.3V_{DD}$	V		
I_Z	Output leakage current	Q: Measurement cct5, INH=LOW	$V_{OH}=V_{DD}$	-	-	10	μA	
			$V_{OL}=GND$	-	-	10	μA	
I_{DD}	Current consumption	Measurement cct 1, 5009AL1-C(f_0),no load INH=open, $f_0=24MHz$	$V_{DD}=2.5V$	-	0.8	1.6	mA	
			$V_{DD}=3.3V$	-	1.1	2.0	mA	
			$V_{DD}=5.0V$	-	1.4	2.8	mA	
		Measurement cct 1, 5009AL2-C($f_0/2$),no load INH=open, $f_0=24MHz$ $f_{OUT}=12MHz$	$V_{DD}=2.5V$	-	0.6	1.2	mA	
			$V_{DD}=3.3V$	-	0.8	1.6	mA	
			$V_{DD}=5.0V$	-	2.5	3.75	mA	
		Measurement cct 1, 5009AL3-C($f_0/4$),no load INH=open, $f_0=24MHz$ $f_{OUT}=6MHz$	$V_{DD}=2.5V$	-	0.6	1.3	mA	
			$V_{DD}=3.3V$	-	0.7	1.5	mA	
			$V_{DD}=5.0V$	-	0.8	1.6	mA	
		Measurement cct 1, 5009AL4-C($f_0/8$),no load INH=open, $f_0=24MHz$ $f_{OUT}=3MHz$	$V_{DD}=2.5V$	-	0.4	0.8	mA	
			$V_{DD}=3.3V$	-	0.5	1.0	mA	
			$V_{DD}=5.0V$	-	0.6	1.2	mA	
		Measurement cct 1, 5009AL5-C($f_0/16$),no load INH=open, $f_0=24MHz$ $f_{OUT}=1.5MHz$	$V_{DD}=2.5V$	-	0.4	0.8	mA	
			$V_{DD}=3.3V$	-	0.4	0.8	mA	
			$V_{DD}=5.0V$	-	0.5	1.0	mA	
		Measurement cct 1, 5009AL6-C($f_0/32$),no load INH=open, $f_0=24MHz$ $f_{OUT}=0.75MHz$	$V_{DD}=2.5V$	-	0.4	0.8	mA	
			$V_{DD}=3.3V$	-	0.4	0.8	mA	
			$V_{DD}=5.0V$	-	0.5	1.0	mA	
		Measurement cct 1, 5009AL6-C($f_0/32$),no load INH=open, $f_0=24MHz$ $f_{OUT}=0.375MHz$	$V_{DD}=2.5V$	-	0.4	0.8	mA	
			$V_{DD}=3.3V$	-	0.4	0.8	mA	
			$V_{DD}=5.0V$	-	0.5	1.0	mA	
		I_{ST}	Standby current	Measurement cct1, INH=LOW	-	-	10	μA
		R_{UP1}	INH pull-up resistance	Measurement cct6	0.4	1.5	8	$M\Omega$
		R_{UP2}			30	70	150	$K\Omega$
R_f	Oscillator feedback resistance	-	70	100	140	$K\Omega$		
C_G	Oscillator capacitance	Design value(a monitor pattern on a wafer is tested),Excluding parasitic capacitance	4.8	6	7.2	pF		
C_D			8	10	12	pF		



AC Electrical Characteristics

XO5009ALx-C Series ($V_{DD}=2.2$ to 5.5 , $T_a=-45$ to 85°C unless otherwise noted)

Parameter	Symbol	Condition	Min	Type	Max	Unit	
Output rise time	t_{r1}	Measurement cct1, $C_L=15\text{pf}$, $0.1V_{DD}$ to $0.9V_{DD}$	$V_{DD}=2.97$ to 3.63 V	-	3.0	5.0	ns
	t_{r2}		$V_{DD}=4.5$ to 5.5 V	-	2.0	3.0	ns
Output fall time	t_{f1}	Measurement cct1, $C_L=15\text{pf}$, $0.1V_{DD}$ to $0.9V_{DD}$	$V_{DD}=2.97$ to 3.63 V	-	3.0	5.0	ns
	t_{f2}		$V_{DD}=4.5$ to 5.5 V	-	2.0	3.0	ns
Output rise time	t_{r1}	Measurement cct1, $C_L=50\text{pf}$, $0.1V_{DD}$ to $0.9V_{DD}$	$V_{DD}=2.97$ to 3.63 V	-	5.0	10	ns
	t_{r2}		$V_{DD}=4.5$ to 5.5 V	-	4.0	8	ns
Output fall time	t_{f1}	Measurement cct1, $C_L=50\text{pf}$, $0.1V_{DD}$ to $0.9V_{DD}$	$V_{DD}=2.97$ to 3.63 V	-	5.0	10	ns
	t_{f2}		$V_{DD}=4.5$ to 5.5 V	-	4.0	8	ns
Output duty cycle	Duty	Measurement cct 1, $T_A=25^\circ\text{C}$, $C_L=15\text{pF}$	45	50	55	%	
Output disable delay time	t_{OD}	Measurement cct 1, $T_A=25^\circ\text{C}$, $C_L \leq 15\text{pF}$	-	-	50	us	

Output switching waveform

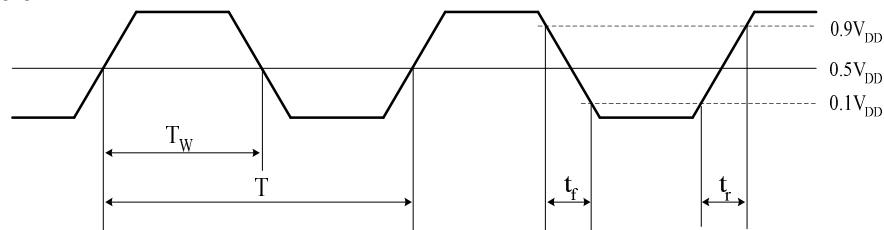

$$\text{DUTY} = T_W / T \times 100 (\%)$$

Output disable and oscillation start timing chart

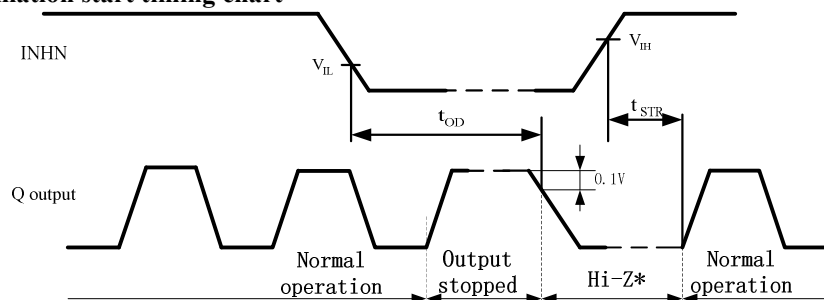

When INHN goes HIGH to LOW, the Q output goes HIGH once and then becomes high impedance.

When INHN goes LOW to HIGH, the Q output from high impedance to normal output operation when the oscillation starts (oscillation is detected)

*: the high-impedance interval in the figure is shown as a LOW level due to the $1\text{K}\Omega$ pull-down resistor connected to the Q pin (see "Measurement circuit 2" in the "Measurement circuits" section)



Measurement Circuit

Measurement cct1

Measurement parameter: I_{DD} , I_{ST} , Duty, t_{is} , t_{f}

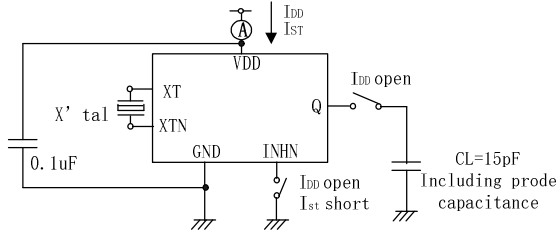

Note: The AC characteristics are observed using an oscilloscope on pin Q

Measurement cct2

Measurement parameter: t_{OD}

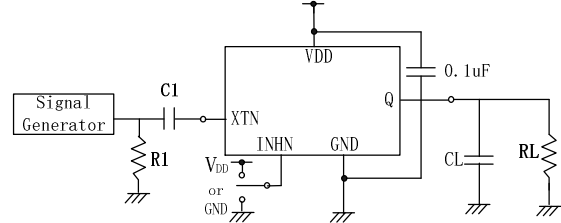

XTN input signal: 1Vp-p, sine wave
C1: 0.001uF CL: 15pF
R1: 50Ω RL: 1KΩ

Measurement cct3

Measurement parameter: V_{OH} , V_{OL}

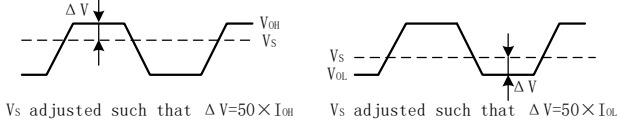
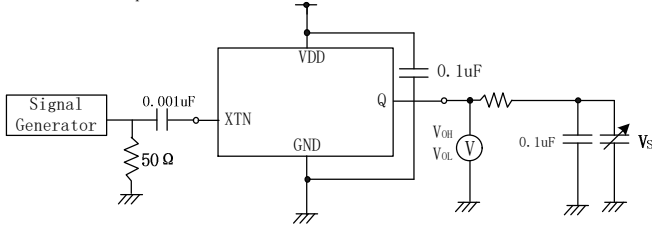

V_S adjusted such that $\Delta V = 50 \times I_{OH}$

V_S adjusted such that $\Delta V = 50 \times I_{OL}$

XTN input signal: 1Vp-p, sine wave

Measurement cct4

Measurement parameter: V_{IH} , V_{IL}

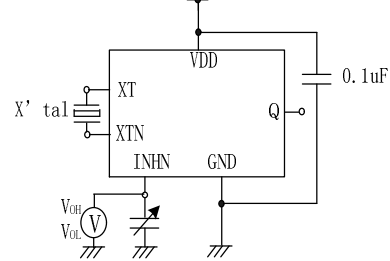

V_{IH} : Voltage is 0V to V_{DD} transition that changes the output state.

V_{IL} : Voltage is V_{DD} to 0V transition that changes the output state.

INHN has an oscillation stop function

Measurement cct5

Measurement parameter: I_Z

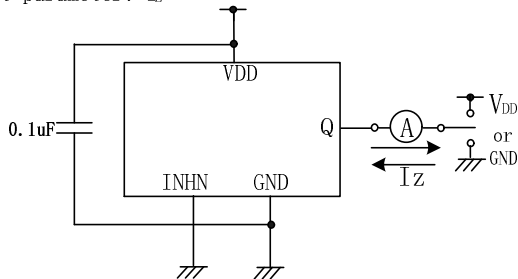

Measurement cct6

Measurement parameter: R_{IP1} , R_{IP2}

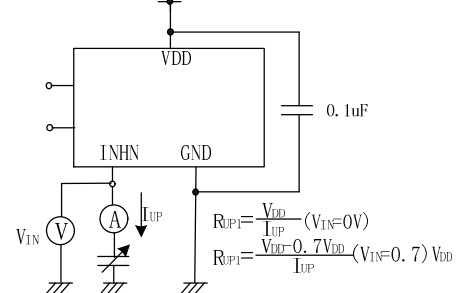

$$R_{IP1} = \frac{V_{DD}}{I_{IP}} \quad (V_{IN} = 0V)$$

$$R_{IP1} = \frac{V_{DD} - 0.7V_{DD}}{I_{IP}} \quad (V_{IN} = 0.7V_{DD})$$



RSM
www.raystar-tek.com

XO5009AL_x-C Series
High Performance
Fundamental Crystal Oscillator IC

Revision	Description	DATE
V1.0	Initial release	2025/3/7
V1.1	Updated XO5009AL2-C IDD($V_{DD}=5.0V$)	2026/3/23