



## Features

- Four 1–200MHz Low-Power (LP) HCSL DIF pairs save 16 resistors; minimal board space and BOM cost
- 62mW typical power consumption in PLL mode; eliminates thermal concerns
- Spread Spectrum (SS) compatible; allows use of SS for EMI reduction
- OE# pins; support DIF power management
- HCSL compatible differential input; can be driven by common clock sources
- Programmable Slew rate for each output; allows tuning for various line lengths
- Programmable output amplitude; allows tuning for various application environments
- Pin/software selectable PLL bandwidth and PLL Bypass; minimize phase jitter for each application
- Outputs blocked until PLL is locked; clean system start-up
- Software selectable 50MHz , 125MHz or 156MHz PLL operation; useful for Ethernet applications
- Configuration can be accomplished with strapping pins; SMBus interface not required for device control
- 3.3V tolerant SMBus interface works with legacy controllers
- Selectable SMBus addresses
- 1.8/3.3V operation voltage
- TQFN-32L-5mm x 5mm

## Applications

- SSD, microServers, WLAN Access points
- Cloud/High-performance Computing
- PCIe Switch

## Description

The RS2CB2204 is a 1.8/3.3V ultra-high performance zero delay and fanout buffers of RSM' full featured PCIe family support PCIe Gen5, Gen6 and Gen7. It has integrated output terminations which can provide  $Z_o = 100\Omega$  or  $85\Omega$  for direct connection for  $100\Omega$  or  $85\Omega$  transmission lines. The device has 4 output enables for clock management and 3 selectable SMBus addresses. In addition, the voltages of VDD and VDDO must be the same.

## Key Specifications

- DIF cycle-to-cycle jitter < 50ps
- DIF output-to-output skew < 50ps
- PCIe Gen7 CC additive phase jitter < 20fs RMS
- 12kHz–20MHz additive phase jitter = 156fs RMS at 156.25M (typical)



## Block Diagram

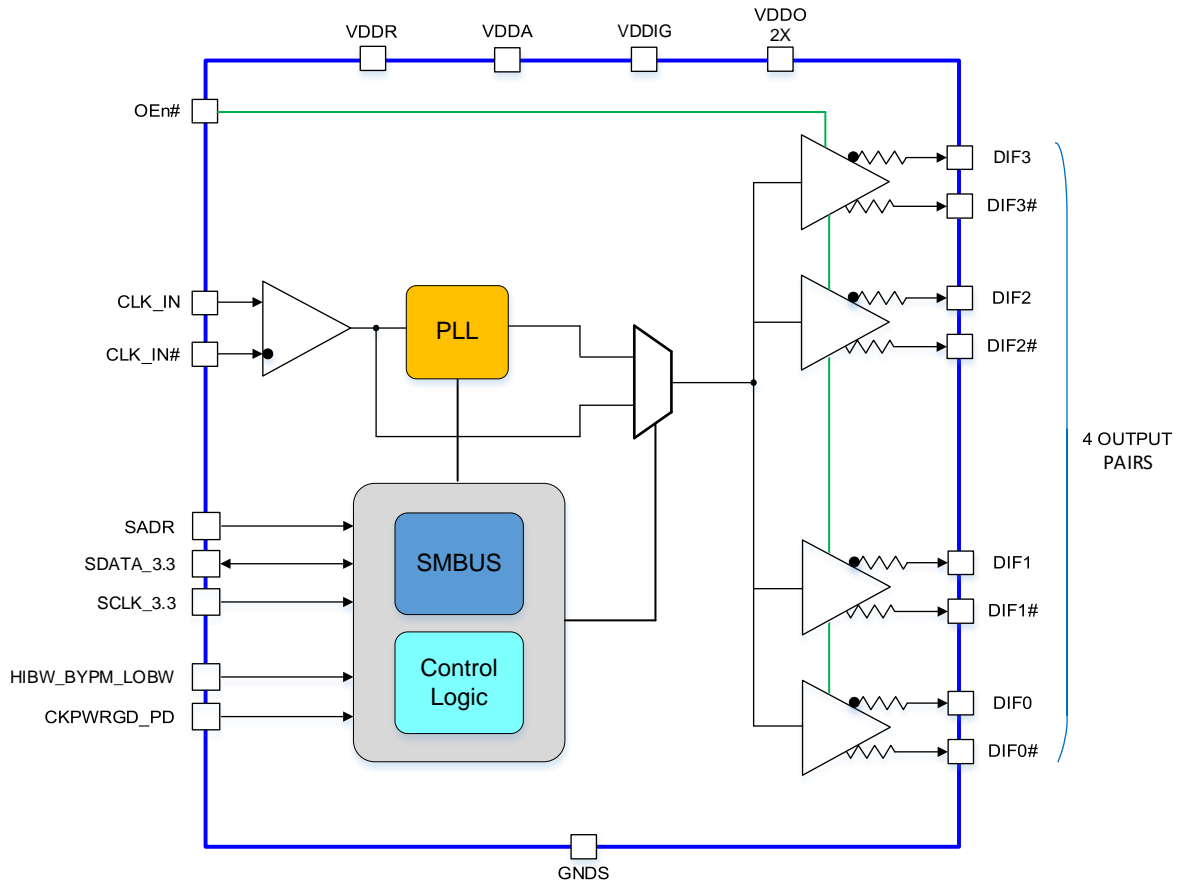



## Ordering Information

Part Number	Package	Description	Differential Output Impedance ( $\Omega$ )	Operation Temperature ( $^{\circ}\text{C}$ )
RS2CB2204ZH	TQFN-32L	5mmx5mmx0.75mm 0.5mm pitch	85	-40~85
RS2CB2204-100ZH	TQFN-32L	5mmx5mmx0.75mm 0.5mm pitch	100	-40~85

## Pin Configuration

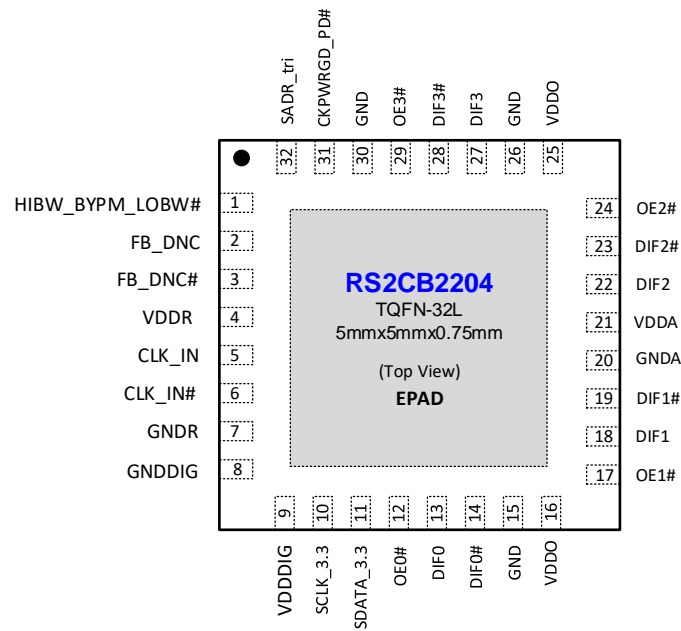



## Pin Descriptions

No.	PIN NAME	TYPE	DESCRIPTION
1	HIBW_BYPM_LOBW#	LATCHED IN	Trilevel input to select High BW, Bypass or Low BW mode. See PLL Operating Mode Table for Details.
2	FB_DNC	DNC	True clock of differential feedback. The feedback output and feedback input are connected internally on this pin. Do not connect anything to this pin.
3	FB_DNC#	DNC	Complement clock of differential feedback. The feedback output and feedback input are connected internally on this pin. Do not connect anything to this pin.
4	VDDR	PWR	1.8/3.3V power for differential input clock (receiver). This VDD should be treated as an Analog power rail and filtered appropriately.
5	CLK_IN	IN	True Input for differential reference clock.
6	CLK_IN#	IN	Complementary Input for differential reference clock.
7	GNDR	GND	Analog Ground pin for the differential input (receiver)
8	GNDDIG	GND	Ground pin for digital circuitry
9	VDDDIG	PWR	1.8/3.3V digital power (dirty power)
10	SCLK_3.3	IN	Clock pin of SMBus circuitry, 3.3V tolerant.
11	SDATA_3.3	I/O	Data pin for SMBus circuitry, 3.3V tolerant.
12	OE0#	IN	Active low input for enabling DIF pair 0. This pin has an internal pull-down. 1 =disable outputs, 0 = enable outputs
13	DIF0	OUT	Differential true clock output
14	DIF0#	OUT	Differential Complementary clock output
15	GND	GND	Ground pin.
16	VDDO	PWR	Power supply, nominal 1.8/3.3V
17	OE1#	IN	Active low input for enabling DIF pair 1. This pin has an internal pull-down. 1 =disable outputs, 0 = enable outputs
18	DIF1	OUT	Differential true clock output
19	DIF1#	OUT	Differential Complementary clock output
20	GNDA	GND	Ground pin for the PLL core.
21	VDDA	PWR	Power supply, nominal 1.8/3.3V
22	DIF2	OUT	Differential true clock output
23	DIF2#	OUT	Differential Complementary clock output
24	OE2#	IN	Active low input for enabling DIF pair 2. This pin has an internal pull-down. 1 =disable outputs, 0 = enable outputs
25	VDDO	PWR	Power supply, nominal 1.8/3.3V
26	GND	GND	Ground pin.
27	DIF3	OUT	Differential true clock output



No.	PIN NAME	TYPE	DESCRIPTION
28	DIF3#	OUT	Differential Complementary clock output
29	OE3#	IN	Active low input for enabling DIF pair 3. This pin has an internal pull-down. 1 =disable outputs, 0 = enable outputs
30	GND	GND	Ground pin.
31	CKPWRGD_PD#	IN	Input notifies device to sample latched inputs and start up on first high assertion. Low enters Power Down Mode, subsequent high assertions exit Power Down Mode. This pin has internal pull-up resistor.
32	SADR_tri	LATCHED IN	Tri-level latch to select SMBus Address. See SMBus Address Selection Table.
33	EPAD		Connect EPAD to ground



### SMBus Address Selection Table

	SADR	Address	+ Read/Write bit
State of SADR on first application of CKPWRGD_PD#	0	1101011	x
	M	1101100	x
	1	1101101	x

### Power Management Table

CKPWRGD_PD#	CLK_IN	SMBus OEx bit	OEx# Pin	DIFx		PLL
				True O/P	Comp. O/P	
0	X	X	X	Low	Low	Off
1	Running	0	X	Low	Low	On <sup>1</sup>
1	Running	1	0	Running	Running	On <sup>1</sup>
1	Running	1	1	Low	Low	On <sup>1</sup>

1. If Bypass mode is selected, the PLL will be off, and outputs will be running.

### Power Connections

VDD	VDDO	GND	Description
4		7	Input receiver analog
9		8	Digital Power
	16,25	15,26, 30	DIF outputs
21		20	PLL Analog

### Frequency Select Table

FSEL Byte3 [4:3]	CLK_IN(MHz)	DIFx (MHz)
00 (Default)	100.00	CLK_IN
01	50.00	CLK_IN
10	125.00	CLK_IN
11	156.25	CLK_IN

### PLL Operating Mode

HiBW_BypM_LoBW#	MODE	Byte1 [7:6] Readback	Byte1 [4:3] Control
0	PLL Lo BW	00	00
M	Bypass	01	01
1	PLL Hi BW	11	11



## Test Loads

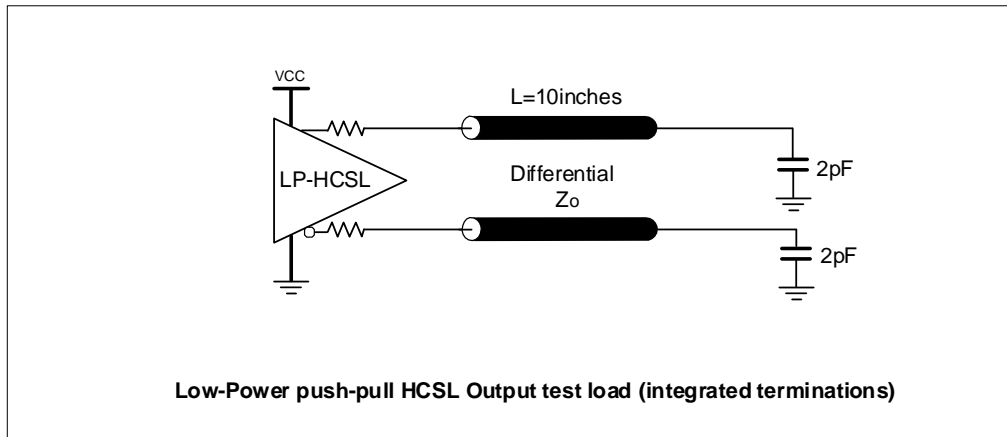



## Absolute Maximum Ratings

Stresses above the ratings listed below can cause permanent damage to the RS2CB2204. These ratings, which are standard values for RSM commercially rated parts, are stress ratings only. Functional operation of the device at these or any other conditions above those indicated in the operational sections of the specifications is not implied. Exposure to absolute maximum rating conditions for extended periods can affect product reliability. Electrical parameters are guaranteed only over the recommended operating temperature range.

PARAMETER	SYMBOL	CONDITIONS	MIN	TYP	MAX	UNITS	NOTES
1.8V Supply Voltage	VDDxx	Applies to VDD, VDDA and VDDIO	-0.5		2.5	V	1,2
Input Voltage	V <sub>IN</sub>		-0.5		V <sub>DD</sub> +0.5V	V	1, 3
Input High Voltage, SMBus	V <sub>IHSMB</sub>	SMBus clock and data pins			3.6V	V	1
Storage Temperature	T <sub>s</sub>		-65		150	°C	1
Junction Temperature	T <sub>j</sub>				125	°C	1
Input ESD protection	ESD prot	Human Body Model	2000			V	1

1. Guaranteed by design and characterization, not 100% tested in production.
2. Operation under these conditions is neither implied nor guaranteed.
3. Not to exceed 2.5V.

## Electrical Characteristics—Clock Input Parameters

T<sub>A</sub> = T<sub>AMB</sub>, Supply Voltages per normal operation conditions, See Test Loads for Loading Conditions

PARAMETER	SYMBOL	CONDITIONS	MIN	TYP	MAX	UNITS	NOTES
Input Common Mode Voltage - DIF_IN	V <sub>COM</sub>	Common Mode Input Voltage	150		1000	mV	1
Input Swing - DIF_IN	V <sub>SWING</sub>	Differential value	300			mV	1
Input Slew Rate - DIF_IN	dv/dt	Measured differentially	0.4		8	V/ns	1,2
Input Leakage Current	I <sub>IN</sub>	V <sub>IN</sub> = VDD , V <sub>IN</sub> = GND	-5		5	uA	
Input Duty Cycle	dt <sub>in</sub>	Measurement from differential waveform	45		55	%	1
Input Jitter - Cycle to Cycle	JDIFIn	Differential Measurement	0		125	ps	1

1. Guaranteed by design and characterization, not 100% tested in production.
2. Slew rate measured through +/-75mV window centered around differential zero.



## Electrical Characteristics–Input/Supply/Common Parameters

TA = T<sub>AMB</sub>, Supply Voltages per normal operation conditions, See Test Loads for Loading Conditions

PARAMETER	SYMBOL	CONDITIONS	MIN	TYP	MAX	UNITS	NOTES
Supply Voltage	V <sub>DDx</sub>	Supply voltage for core and analog	1.71	1.8/3.3	3.63	V	
Ambient Operating Temperature	T <sub>AMB</sub>	Commercial range	0	25	70	°C	
		Industrial range	-40	25	85	°C	
Input High Voltage	V <sub>IH</sub>	Single-ended inputs, except SMBus	0.75 V <sub>DD</sub>		V <sub>DD</sub> + 0.3	V	
Input Mid Voltage	V <sub>IM</sub>	Single-ended tri-level inputs ('_tri' suffix)	0.4 V <sub>DD</sub>		0.55 V <sub>DD</sub>	V	
Input Low Voltage	V <sub>IL</sub>	Single-ended inputs, except SMBus	-0.3		0.25 V <sub>DD</sub>	V	
Input Current	I <sub>IN</sub>	Single-ended inputs, V <sub>IN</sub> = GND, V <sub>IN</sub> = V <sub>DD</sub>	-5		5	uA	
	I <sub>INP</sub>	Single-ended inputs V <sub>IN</sub> = 0 V; Inputs with internal pull-up resistors V <sub>IN</sub> = V <sub>DD</sub> ; Inputs with internal pull-down resistors	-200		200	uA	
Input Frequency	F <sub>ibyp</sub>	Bypass mode	1		200	MHz	2
	F <sub>ipll</sub>	100MHz PLL mode	97	100.00	104	MHz	2
	F <sub>ipll</sub>	125MHz PLL mode	120	125.00	130	MHz	2
	F <sub>ipll</sub>	50MHz PLL mode	49	50.00	52	MHz	2
Pin Inductance	L <sub>pin</sub>				7	nH	1
Capacitance	C <sub>IN</sub>	Logic Inputs, except DIF_IN	1.5		5	pF	1
	C <sub>INDIF_IN</sub>	DIF_IN differential clock inputs	1.5		2.7	pF	1,5
	C <sub>OUT</sub>	Output pin capacitance			6	pF	1
Clk Stabilization	T <sub>STAB</sub>	From V <sub>DD</sub> Power-Up and after input clock stabilization or de-assertion of PD# to 1st clock		0.6	1	ms	1,2
Input SS Modulation Frequency PCIe	f <sub>MODINPCIe</sub>	Allowable Frequency for PCIe Applications (Triangular Modulation)	30		33	kHz	
Input SS Modulation Frequency non-PCIe	f <sub>MODIN</sub>	Allowable Frequency for non-PCIe Applications (Triangular Modulation)	0		66	kHz	
OE# Latency	t <sub>LATOE#</sub>	DIF start after OE# assertion DIF stop after OE# deassertion	1		3	clocks	1,3
Tdrive_PD#	t <sub>DRVPD</sub>	DIF output enable after PD# de-assertion			300	us	1,3
Tfall	t <sub>F</sub>	Fall time of single-ended control inputs			5	ns	2
Trise	t <sub>R</sub>	Rise time of single-ended control inputs				ns	2
SMBus Input Low Voltage	V <sub>ILSMB</sub>	V <sub>DD</sub> SMB = 3.3V, see note 4 for V <sub>DD</sub> SMB < 3.3V			0.6	V	
SMBus Input High Voltage	V <sub>IHSMB</sub>	V <sub>DD</sub> SMB = 3.3V, see note 5 for V <sub>DD</sub> SMB < 3.3V	2.1		3.6	V	4
SMBus Output Low Voltage	V <sub>OLSMB</sub>	@ I <sub>PULLUP</sub>			0.4	V	



PARAMETER	SYMBOL	CONDITIONS	MIN	TYP	MAX	UNITS	NOTES
SMBus Sink Current	$I_{PULLUP}$	@ $V_{OL}$	4			mA	
Nominal Bus Voltage	$V_{DDSMB}$	Bus Voltage	1.7		3.6	V	
SCLK/SDATA Rise Time	$t_{RSMB}$	(Max $V_{IL} - 0.15$ ) to (Min $V_{IH} + 0.15$ )			1000	ns	1
SCLK/SDATA Fall Time	$t_{FSMB}$	(Min $V_{IH} + 0.15$ ) to (Max $V_{IL} - 0.15$ )			300	ns	1
SMBus Frequency	$f_{MAXSMB}$	Maximum SMBus operating frequency			400	kHz	6

1. Guaranteed by design and characterization, not 100% tested in production.
2. Control input must be monotonic from 20% to 80% of input swing.
3. Time from deassertion until outputs are > 200 mV.
4. For  $V_{DDSMB} < 3.3V$ ,  $V_{IHSMB} \geq 0.8 \times V_{DDSMB}$ .
5. DIF\_IN input.
6. The differential input clock must be running for the SMBus to be active.



## Electrical Characteristics–Low Power HCSL Outputs

TA = T<sub>AMB</sub>, Supply Voltages per normal operation conditions, See Test Loads for Loading Conditions

PARAMETER	SYMBOL	CONDITIONS	MIN	TYP	MAX	UNITS	NOTES
Slew rate	dV/dt	Scope averaging on, fast setting	1.7	2.8	4	V/ns	1,2,3
	dV/dt	Scope averaging on, slowsetting	1.1	2.1	3.2	V/ns	1,2,3
Slew rate matching	ΔdV/dt	Slew rate matching, Scope averaging on		6.2	20	%	1,2,4
Voltage High	V <sub>HIGH</sub>	Statistical measurement on single-ended signal using oscilloscope math function. (Scope averaging on)	660	789	850	mV	7
Voltage Low	V <sub>LOW</sub>		-150	38	150		7
Max Voltage	V <sub>max</sub>	Measurement on single ended signal using absolute value. (Scope averaging off)		803	1150	mV	7
Min Voltage	V <sub>min</sub>		-300	15			7
Crossing Voltage(abs)	V <sub>cross_abs</sub>	Scope averaging off	250	417	550	mV	1,5
Crossing Voltage(var)	Δ-V <sub>cross</sub>	Scope averaging off		13	140	mV	1,6

1. Guaranteed by design and characterization, not 100% tested in production.
2. Measured from differential waveform
3. Slew rate is measured through the Vswing voltage range centered around differential 0V. This results in a +/-150mV window around differential 0V.
4. Matching applies to rising edge rate for Clock and falling edge rate for Clock#. It is measured using a +/-75mV window centered on the average cross point where Clock rising meets Clock# falling. The median cross point is used to calculate the voltage thresholds the oscilloscope is to use for the edge rate calculations.
5. V<sub>cross</sub> is defined as voltage where Clock = Clock# measured on a component test board and only applies to the differential rising edge (i.e. Clock rising and Clock# falling).
6. The total variation of all V<sub>cross</sub> measurements in any particular system. Note that this is a subset of V<sub>cross\_min/max</sub> (V<sub>cross absolute</sub>) allowed. The intent is to limit V<sub>cross</sub> induced modulation by setting Δ-V<sub>cross</sub> to be smaller than V<sub>cross absolute</sub>.
7. At default SMBus settings.

## Electrical Characteristics–Current Consumption

TA = T<sub>AMB</sub>, Supply Voltages per normal operation conditions, See Test Loads for Loading Conditions

PARAMETER	SYMBOL	CONDITIONS	MIN	TYP	MAX	UNITS	NOTES
Operating Supply Current	I <sub>DDA</sub>	VDDA+VDDR, PLL Mode, @100MHz		10.6	15	mA	1
	I <sub>DDO</sub>	VDD, All outputs active @100MHz		16	25	mA	1
Powerdown Current	I <sub>DDAPD</sub>	VDDA+VDDR, PLL Mode, @100MHz		0.1	0.5	mA	1, 2
	I <sub>DDOPD</sub>	VDD, Outputs Low/Low			1.2	mA	1, 2

1. Guaranteed by design and characterization, not 100% tested in production.
2. Input clock stopped.



## Electrical Characteristics–Output Duty Cycle, Jitter, Skew and PLL Characteristics

T<sub>A</sub> = T<sub>AMB</sub>, Supply Voltages per normal operation conditions, See Test Loads for Loading Conditions

PARAMETER	SYMBOL	CONDITIONS	MIN	TYP	MAX	UNITS	NOTES
PLL Bandwidth	BW	-3dB point in High BW Mode	2	2.7	4	MHz	1,5
		-3dB point in Low BW Mode	1	1.4	2	MHz	1,5
PLL Jitter Peaking	t <sub>JPEAK</sub>	Peak Pass band Gain		1.1	2	dB	1
Duty Cycle	t <sub>DC</sub>	Measured differentially, PLL Mode	45	50	55	%	1
Duty Cycle Distortion	t <sub>DCD</sub>	Measured differentially, Bypass Mode @100MHz	-1	0.03	1	%	1,3
Skew, Input to Output	t <sub>pdBYP</sub>	Bypass Mode, V <sub>T</sub> = 50%	2000	2500	3000	ps	1
	t <sub>pdPLL</sub>	PLL Mode V <sub>T</sub> = 50%	-100	-4	100	ps	1,4
Skew, Output to Output	t <sub>sk3</sub>	V <sub>T</sub> = 50%		90	200	ps	1,4
Jitter, Cycle to cycle	t <sub>jcyc-cyc</sub>	PLL mode		14	50	ps	1,2
		Additive Jitter in Bypass Mode		0.10	25	ps	1,2

1. Guaranteed by design and characterization, not 100% tested in production.
2. Measured from differential waveform
3. Duty cycle distortion is the difference in duty cycle between the output and the input clock when the device is operated in bypass mode.
4. All outputs at default slew rate
5. The MIN/TYP/MAX values of each BW setting track each other, i.e., Low BW MAX will never occur with Hi BW MIN.

## Electrical Characteristics–Phase Jitter Parameters – 12kHz to 20MHz

T<sub>AMB</sub> = over the specified operating range. Supply Voltages per normal operation conditions. See Test Loads for loading conditions.

PARAMETER	SYMBOL	CONDITIONS	MIN	TYP	MAX	Specification Limit	UNITS	NOTES
12k-20M Additive Phase Jitter, Fan-out Buffer Mode	t <sub>jph12k-20MFOB</sub>	Fan-out Buffer Mode, SSC OFF, 156.25MHz		156		n/a	fs(rms)	1, 2, 3

Notes:

1. Applies to all differential outputs, guaranteed by design and characterization. See Test Loads for measurement setup details.
2. 12kHz to 20M Hz brick wall filter.
3. For RMS values additive jitter is calculated by solving for b where  $[b = \sqrt{c^2 - a^2}]$ , a is rms input jitter and c is rms total jitter.



## Electrical Characteristics—Additive PCIe Phase Jitter for Fanout Buffer Mode<sup>[7]</sup>

TAMB = over the specified operating range. Supply Voltages per normal operation conditions. See Test Loads for loading conditions.

PARAMETER	SYMBOL	CONDITIONS	MIN	TYP	MAX	Limit	UNITS	NOTES
Additive PCIe Phase Jitter, Fan-out Buffer Mode (Common Clocked Architecture)	tjphPCIeG1-CC	PCIe Gen 1 (2.5 GT/s)		1.7	3.0	86	ps (p-p)	1, 2
	tjphPCIeG2-CC	PCIe Gen 2 Lo Band (5.0 GT/s)		0.02	0.03	3	ps (RMS)	1, 2
		PCIe Gen 2 Hi Band (5.0 GT/s)		0.122	0.199	3.1	ps (RMS)	1, 2
	tjphPCIeG3-CC	PCIe Gen 3 (8.0 GT/s)		0.059	0.098	1	ps (RMS)	1, 2
	tjphPCIeG4-CC	PCIe Gen 4 (16.0 GT/s)		0.059	0.098	0.5	ps (RMS)	1, 2, 3, 4
	tjphPCIeG5-CC	PCIe Gen 5 (32.0 GT/s)		0.023	0.038	0.15	ps (RMS)	1, 2, 3, 5
	tjphPCIeG6-CC	PCIe Gen 6 (64.0 GT/s)		0.015	0.02	0.1	ps (RMS)	1, 2, 3, 5
	tjphPCIeG7-CC	PCIe Gen 7 (128.0 GT/s)		0.01	0.012	0.067	ps (RMS)	1, 2, 3, 5
Additive PCIe Phase Jitter, Fan-out Buffer Mode (SRIS Architecture)	tjphPCIeG1-SRIS	PCIe Gen 1 (2.5 GT/s)		0.175	0.038	n/a	ps (RMS)	1, 2, 6
	tjphPCIeG2-SRIS	PCIe Gen 2 (5.0 GT/s)		0.156	0.275	n/a	ps (RMS)	1, 2, 6
	tjphPCIeG3-SRIS	PCIe Gen 3 (8.0 GT/s)		0.041	0.247	n/a	ps (RMS)	1, 2, 6
	tjphPCIeG4-SRIS	PCIe Gen 4 (16.0 GT/s)		0.043	0.064	n/a	ps (RMS)	1, 2, 6
	tjphPCIeG5-SRIS	PCIe Gen 5 (32.0 GT/s)		0.036	0.066	n/a	ps (RMS)	1, 2, 6
	tjphPCIeG6-SRIS	PCIe Gen 6 (64.0 GT/s)		0.012	0.02	n/a	ps (RMS)	1, 2, 6
	tjphPCIeG7-SRIS	PCIe Gen 7 (128.0 GT/s)		0.01	0.015	n/a	ps (RMS)	1, 2, 6

**Notes:**

- The Refclk jitter is measured after applying the filter functions found in PCI Express Base Specification 7.0, Revision 1.0. See the Test Loads section of the data sheet for the exact measurement setup. The total Ref Clk jitter limits for each data rate are listed for convenience. The worst-case results for each data rate are summarized in this table. If oscilloscope data is used, equipment noise is removed from all results.
- Jitter measurements shall be made with a capture of at least 100,000 clock cycles captured by a real-time oscilloscope (RTO) with a sample rate of 20 GS/s or greater. Broadband oscilloscope noise must be minimized in the measurement. The measured PP jitter is used (no extrapolation) for RTO measurements. Alternately -Jitter measurements may be used with a Phase Noise Analyzer (PNA) extending (flat) and integrating and folding the frequency content up to an offset from the carrier frequency of at least 200 MHz (at 300 MHz absolute frequency) below the Nyquist frequency. For PNA measurements for the 2.5 GT/s data rate, the RMS jitter is converted to peak-to-peak jitter using a multiplication factor of 8.83. In the case where real-time oscilloscope and PNA measurements have both been done and produced different results the RTO result must be used.
- SSC spurs from the fundamental and harmonics are removed up to a cutoff frequency of 2 MHz taking care to minimize removal of any non-SSC content.
- Note that 0.7 ps RMS is to be used in channel simulations to account for additional noise in a real system.
- Note that 0.25 ps RMS is to be used in channel simulations to account for additional noise in a real system.
- The PCI Express Base Specification 7.0, Revision 1.0 provides the filters necessary to calculate SRIS jitter values, however, it does not provide specification limits, hence the n/a in the Limit column. SRIS values are informative only. In general, a clock operating in an SRIS system must be twice as good as a clock operating in a Common Clock system. For RMS values, twice as good is equivalent to dividing the CC value by  $\sqrt{2}$ . And additional consideration is the value for which to divide by  $\sqrt{2}$ . The conservative approach is to divide the ref clock jitter limit, and the case can be made for dividing the channel simulation values by  $\sqrt{2}$ , if the ref clock is close to the Tx clock input. An example for Gen4 is as follows. A "rule-of-thumb" SRIS limit would be either  $0.5\text{ps RMS}/\sqrt{2} = 0.35\text{ps RMS}$  if the clock chip is far from the clock input, or  $0.7\text{ps RMS}/\sqrt{2} = 0.5\text{ps RMS}$  if the clock chip is near the clock input.
- Additive jitter for RMS values is calculated by solving for b where  $b = \sqrt{c^2 - a^2}$ , and a is rms input jitter and c is rms output jitter.



## SMBus Interface

### Write Sequence

- Controller (host) sends a start bit
- Controller (host) sends the write address
- RS2CB2204 clock will **acknowledge**
- Controller (host) sends the beginning byte Location= N
- RS2CB2204 clock will **acknowledge**
- Controller (host) sends the byte count = X
- RS2CB2204 clock will **acknowledge**
- Controller (host) starts sending Byte **N through Byte N+X-1**
- RS2CB2204 clock will **acknowledge** each byte one at a time
- Controller (host) sends a stop bit

Index Block Write Operation		
Controller (Host)		RS2CB2204 (Slave/Receiver)
T	start bit	
Slave Address		
WR	Write	
		ACK
Beginning Byte = N		
		ACK
Data Byte Count = X		
		ACK
Beginning Byte N		
		ACK
O		
O		O
O		O
		O
Byte N + X - 1		
		ACK
P	stop bit	



**Read Sequence**

- Controller (host) will send a start bit
- Controller (host) sends the write address
- RS2CB2204 clock will **acknowledge**
- Controller (host) sends the beginning byte Location= N
- RS2CB2204 clock will **acknowledge**
- Controller (host) will send a separate start bit
- Controller (host) sends the read address
- RS2CB2204 clock will **acknowledge**
- RS2CB2204 clock will send the data byte count = X
- RS2CB2204 clock sends **Byte N+X-1**
- RS2CB2204 clock sends **Byte L through Byte X (if X(H) was written to Byte 7)**
- Controller (host) will need to acknowledge each byte
- Controller (host) will send a not acknowledge bit
- Controller (host) will send a stop bit

Index Block Read Operation		
Controller (Host)		RS2CB2204 (Slave/Receiver)
T	start bit	
Slave Address		
WR	Write	
		ACK
Beginning Byte = N		
		ACK
RT	Repeat start	
Slave Address		
RD	Read	
		ACK
		Data Byte Count=X
ACK		
		Beginning Byte N
ACK		
O		O
O		O
O		O
		Byte N + X - 1
N	Not	
P	stop bit	



**SMBus Table: Output Enable Register <sup>1</sup>**

Byte 0	Name	Control Function	Type	0	1	Default
Bit 7	Reserved					1
Bit 6	DIF OE3	Output Enable	RW	Low/Low	OE3#control	1
Bit 5	DIF OE2	Output Enable	RW	Low/Low	OE2#control	1
Bit 4	Reserved					1
Bit 3	DIF OE1	Output Enable	RW	Low/Low	OE1#control	1
Bit 2	Reserved					1
Bit 1	DIF OE0	Output Enable	RW	Low/Low	OE0#control	1
Bit 0	Reserved					1

1. A low on these bits will override the OE# pin and force the differential output Low/Low

**SMBus Table: PLL Operating Mode and Output Amplitude Control Register**

Byte 1	Name	Control Function	Type	0	1	Default
Bit 7	PLLMODERB1	PLL Mode Readback Bit 1	R	See PLL Operating Mode Table		Latch
Bit 6	PLLMODERB0	PLL Mode Readback Bit 0	R			Latch
Bit 5	PLLMODE_SWCNTRL	Enable SW control of PLL Mode	RW	Values in B1[7:6] set PLL Mode	Values in B1[4:3] set PLL Mode	0
Bit 4	PLLMODE1	PLL Mode Control Bit 1	RW <sup>1</sup>	See PLL Operating Mode Table		0
Bit 3	PLLMODE0	PLL Mode Control Bit 0	RW <sup>1</sup>			0
Bit 2	Reserved					1
Bit 1	AMPLITUDE 1	Controls Output Amplitude	RW	00 = 0.6V	01 = 0.7V	1
Bit 0	AMPLITUDE 0		RW	10 = 0.8V	11 = 0.9V	0

1. B1[5] must be set to a 1 for these bits to have any effect on the part.

**SMBus Table: DIF Slew Rate Control Register**

Byte 2	Name	Control Function	Type	0	1	Default
Bit 7	Reserved					1
Bit 6	SLEWRATESEL DIF3	Adjust Slew Rate of DIF6	RW	2V/ns	3V/ns	1
Bit 5	SLEWRATESEL DIF2	Adjust Slew Rate of DIF5	RW	2V/ns	3V/ns	1
Bit 4	Reserved					1
Bit 3	SLEWRATESEL DIF1	Adjust Slew Rate of DIF3	RW	2V/ns	3V/ns	1
Bit 2	Reserved					1
Bit 1	SLEWRATESEL DIF0	Adjust Slew Rate of DIF1	RW	2V/ns	3V/ns	1
Bit 0	Reserved					1

**SMBus Table: Frequency Select Control Register**

Byte 3	Name	Control Function	Type	0	1	Default
Bit 7	Reserved					1
Bit 6	Reserved					1
Bit 5	FREQ_SEL_EN	Enable SW selection of frequency	RW	SW frequency change disabled	SW frequency change enabled	0
Bit 4	FSEL1	Freq. Select Bit 1	RW <sup>1</sup>	See Frequency Select Table		0
Bit 3	FSEL0	Freq. Select Bit 0	RW <sup>1</sup>			0
Bit 2	Reserved					1
Bit 1	Reserved					1
Bit 0	SLEWRATESEL FB	Adjust Slew Rate of FB	RW	2V/ns	3V/ns	1

1. B3[5] must be set to a 1 for these bits to have any effect on the part.

**Byte 4 is Reserved and reads back 'hFF'**



**SMBus Table: Revision and Vendor ID Register**

Byte 5	Name	Control Function	Type	0	1	Default
Bit 7	RID3	Revision ID	R	A rev = 0000		0
Bit 6	RID2		R			0
Bit 5	RID1		R			0
Bit 4	RID0		R			0
Bit 3	VID3	VENDOR ID	R	0001 = <b>RSM</b>		0
Bit 2	VID2		R			0
Bit 1	VID1		R			0
Bit 0	VID0		R			1

**SMBus Table: Device Type/Device ID**

Byte 6	Name	Control Function	Type	0	1	Default
Bit 7	Device Type1	Device Type	R	00 = FGx, 01 = DBx, 10 = DMx, 11= Reserved		0
Bit 6	Device Type0		R			1
Bit 5	Device ID5	Device ID	R	000100 binary or 04 hex		0
Bit 4	Device ID4		R			0
Bit 3	Device ID3		R			0
Bit 2	Device ID2		R			1
Bit 1	Device ID1		R			0
Bit 0	Device ID0		R			0

**SMBus Table: Byte Count Register**

Byte 7	Name	Control Function	Type	0	1	Default
Bit 7	Reserved					0
Bit 6	Reserved					0
Bit 5	Reserved					0
Bit 4	BC4	Byte Count Programming	RW	Writing to this register will configure how many bytes will be read back, default is = 8 bytes.		0
Bit 3	BC3		RW			1
Bit 2	BC2		RW			0
Bit 1	BC1		RW			0
Bit 0	BC0		RW			0



## Package Information

### TQFN-32L

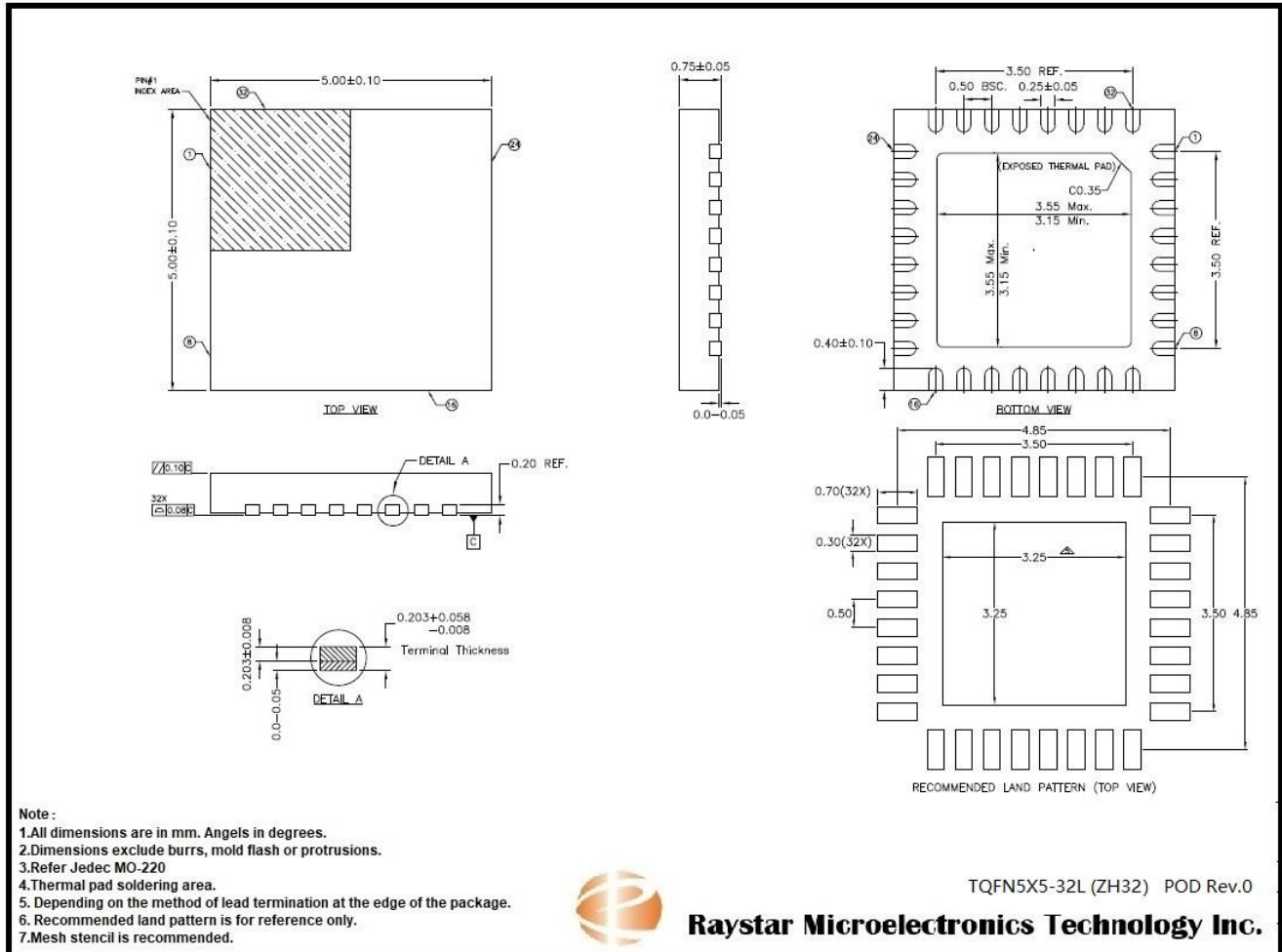

**Note:**

1. All dimensions are in mm. Angles in degrees.
2. Dimensions exclude burrs, mold flash or protrusions.
3. Refer Jeduc MO-220
4. Thermal pad soldering area.
5. Depending on the method of lead termination at the edge of the package.
6. Recommended land pattern is for reference only.
7. Mesh stencil is recommended.





## Revision History

Revision	Description	Date
1.0	Initial release	2025/11/14
1.1	Add 3.3V Data	2026/03/26