



## Features

- 10 to 50 MHz input frequency ranges
- Operating voltages of 1.62 V to 3.63V
- Spreading Ratio:  
-2.0%,-1.5%,-1.0%,-0.8%
- Modulation Rate: Fin / 764
- Low power consumption and dissipation

## Benefits

- Reduction in EMI
- System cost saving
- Reduced system complexity
- Faster time to market

## Block Diagram

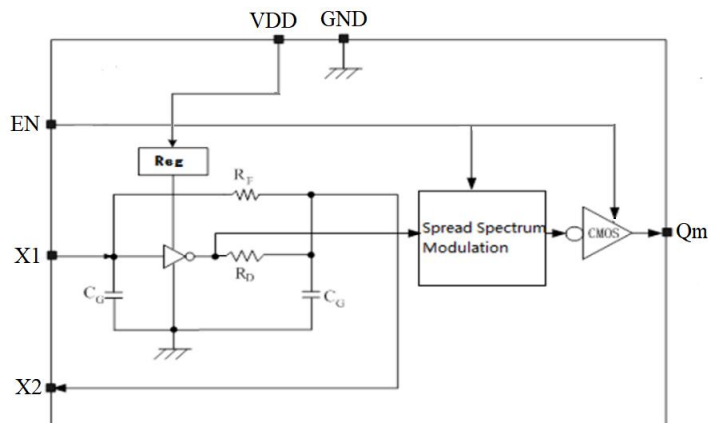

## Description

The RS1XOS6201ZAE is one Low Power Spread Spectrum Frequency Multiplier part of RSM SSC family. The output frequency is same as crystal, and is designed to reduce electromagnetic interference (EMI) by spreading the clock.

The Spreading Mode/Ratio is programmed in fab by ROM codes. The RS1XOS6201ZAE provides spread, refer to different option.

## Applications

- IP Camera
- Printers/MFPs
- Media players
- DTV/Set-top Box
- Embedded digital video devices
- LCD Panel Modules
- Automotive components
- Networking devices
- Surveillance

## Order Information

Part no.	Package type
RS1XOS6201-xxZAE	DFN2*2-8L

Note: xx: -AC: -2%, AE: -1.5%, AF: -1%, BF: -0.8%



## Pin Function

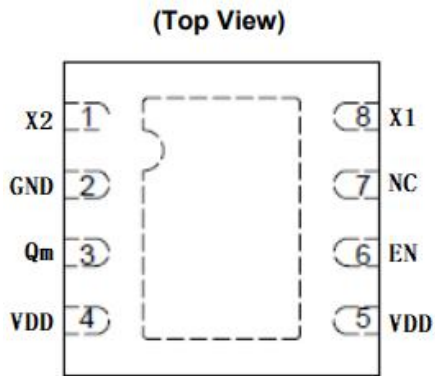

## Pad Description

Pin Name	I/O Type	Description
OE	I	Output Enable/Disable or Spreading Enable/Disable control by 3 states; Low: Qm output Hiz; High: Qm output with spreading >VDD + 1V: Qm output without spreading.
XIN	I	Crystal input pad.
XOUT	O	Crystal output pad.
GND	GND	Ground.
Qm	O	Spread spectrum clock output(OE=VDD).
VDD	Power	Power supply.



## Order Information

**RS1XOS6201-xxZAE - 25.000000 MHz - D - 20 - P - H**  
 ①                                  ②                                  ③    ④    ⑤    ⑥

①: Model    ②: Output Frequency    ③: Spread type  
 ④: Spread width    ⑤: Function    ⑥: Operating temperature

③: Spread type	
C	Center Spread
D	Down Spread

④: Spread width		
	Center Spread	Down Spread
20	-	-2.0%
15	-	-1.5%
10	-	-1.0%
08	-	-0.8%

⑤: Function	
P	Output enable

⑥: Operating temperature	
G	-40°C to +85°C
H	-40°C to +105°C
A	-40°C to +125°C



## Maximum Rating

Supply Voltage to Ground Potential.....	4V
OE pin .....	VDD+2V
Other Inputs and Output.....	VDD+0.5V
Storage Temperature.....	-65°C to +150°C

**Note:**  
Stresses greater than those listed under MAXIMUM RATINGS may cause permanent damage to the device. This is a stress rating only and functional operation of the device at these or any other conditions above those indicated in the operational sections of this specification is not implied. Exposure to absolute maximum rating conditions for extended periods may affect reliability.

## Recommended Operating Conditions

(GND=0V, unless otherwise noted.)

Sym.	Parameter	Conditions	Min	Typ	Max	Unit
V <sub>DD</sub>	Supply voltage	-	1.62	-	3.63	V
T <sub>A</sub>	Operating temperature	-	-40		+125	°C
f <sub>0</sub>	Oscillation frequency*1	-	16	27	40	MHz

## DC Characteristics

V<sub>DD</sub>= 1.62V to 3.63V, Ambient Temperature -40 to +125°C

Symbol	Parameter	Conditions	Min.	Typ.	Max.	Unit
V <sub>DD</sub>	Operating voltage	-	1.62	-	3.63	V
V <sub>OH</sub>	Output high voltage	V <sub>DD</sub> =1.8V, I <sub>OH</sub> = -1mA	V <sub>DD</sub> -0.4			V
		V <sub>DD</sub> =2.5V, I <sub>OH</sub> = -1mA	V <sub>DD</sub> -0.4	-	-	V
		V <sub>DD</sub> =3.3V, I <sub>OH</sub> = -1mA	V <sub>DD</sub> -0.4	-	-	V
V <sub>OL</sub>	Output low voltage	V <sub>DD</sub> =1.8V, I <sub>OL</sub> = 1mA			0.4	V
		V <sub>DD</sub> =2.5V, I <sub>OL</sub> = 1mA	-	-	0.4	V
		V <sub>DD</sub> =3.3V, I <sub>OL</sub> = 1mA	-	-	0.4	V
V <sub>IH</sub>	HIGH-level input voltage	OE Measurement	0.7V <sub>DD</sub>			V
V <sub>IL</sub>	LOW-level input voltage	OE Measurement			0.3V <sub>DD</sub>	V
IDD1	Supply current1	V <sub>DD</sub> =1.8V, OE=V <sub>DD</sub> ;27MHz/15pf		2	4	mA
		V <sub>DD</sub> =2.5V, OE=V <sub>DD</sub> ;27MHz/15pf		2.5	5	mA
		V <sub>DD</sub> =3.3V, OE=V <sub>DD</sub> ;27MHz/15pf		3.0	6	mA
IDD2	Supply current2	V <sub>DD</sub> =1.8V, OE>V <sub>DD</sub> +1V,27MHz/15pf		1.3	3	mA
		V <sub>DD</sub> =2.5V, OE>V <sub>DD</sub> +1V,27MHz/15pf		1.7	3.5	mA
		V <sub>DD</sub> =3.3V, OE>V <sub>DD</sub> +1V,27MHz/15pf		2.1	4	mA



## AC Characteristics

VDD= 1.62V to 3.63V, Ambient Temperature -40 to +125°C

Symbol	Parameter	Conditions	Min.	Typ.	Max.	Unit
X <sub>IN</sub> , X <sub>OUT</sub>	Crystal input frequency range		16	–	40	MHz
t <sub>Rise</sub>	Output rise time (25MHz)	Measured from 20% to 80% VDD=1.8V, Load=15pf		2.4	5	ns
		Measured from 10% to 90% VDD=2.5V, Load=15pf		2.4	5	ns
		Measured from 10% to 90% VDD=3.3V, Load=15pf	–	2	5	ns
t <sub>Fall</sub>	Output fall time (25MHz)	Measured from 80% to 20% VDD=1.8V, Load=15pf		2.6	5	ns
		Measured from 90% to 10% VDD=2.5V, Load=15pf		2.4	5	ns
		Measured from 90% to 10% VDD=3.3V, Load=15pf	–	2	5	ns
Duty cycle	Output duty cycle	Load=15pf, 50%VDD	45	50	55	%

**Note:** Typical condition is on room temperature at 25°



## Measurement Circuit

Measurement parameter:  $I_{DD}$ , Duty,  $t_r$ ,  $t_f$

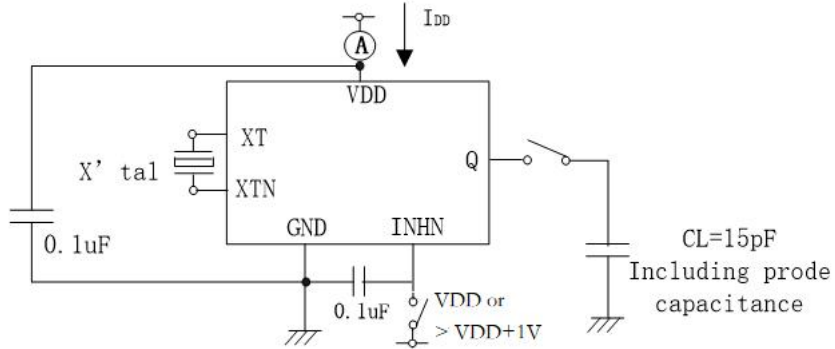

Note: The AC characteristics are observed using an oscilloscope on pin Q

## Output switching waveform

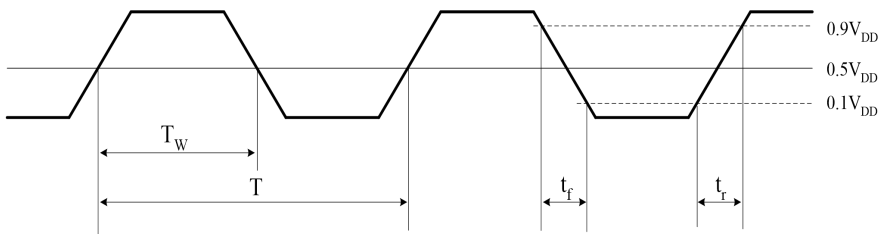

$$\text{DUTY} = T_W / T \times 100 (\%)$$

## Application Circuit

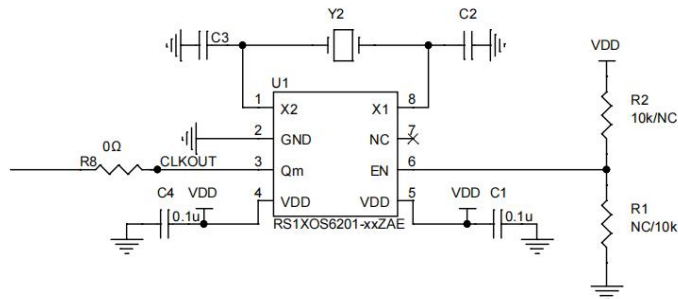



**Package Dimension**  
**DFN 2X2X0.75-8L(0.5 pitch) ZA08**

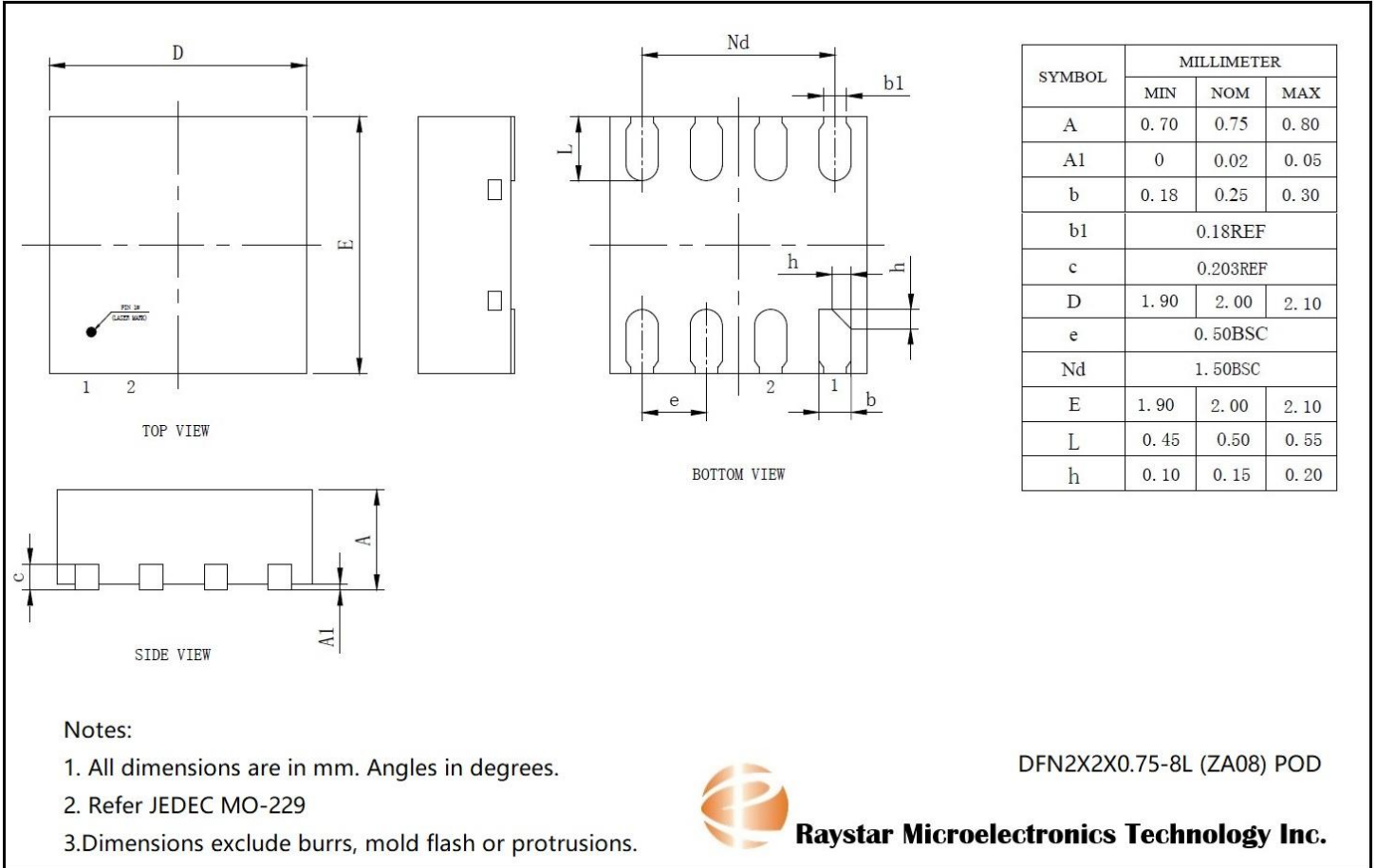

**Revision History**

Revision	Description	Date
0	Initiated	2023/5/25
1.0	Updated format and official release	2024/12/03
1.1	Add application circuitry, Add Order Information	2025/4/14