



Features

- 24/25/26 MHz input frequency
XO6301: 24MHz fundamental crystal
XO6302: 25MHz fundamental crystal
XO6303: 26MHz fundamental crystal
- Operating voltages of 1.62 V to 3.63V
- Dual output (32.768kHz+MHz output)
- Mode function available (Single output (32.768kHz) or Dual output (32.768kHz+MHz) is selectable.)
- Output Specification: CMOS
- 50±5% output duty cycle
- 15pF output drive: -40~85°C
- Die form or Wafer form

Applications

- Bluetooth Low Energy (BLE) communication function
- Wearable devices, and compact and thin devices such as smartphone and tablet
- Devices both with clock signal source for microcomputer and clock function other than above.
- Fundamental Crystal Oscillator
- 7050, 5032, 3225, 2520, 2016

Block Diagram

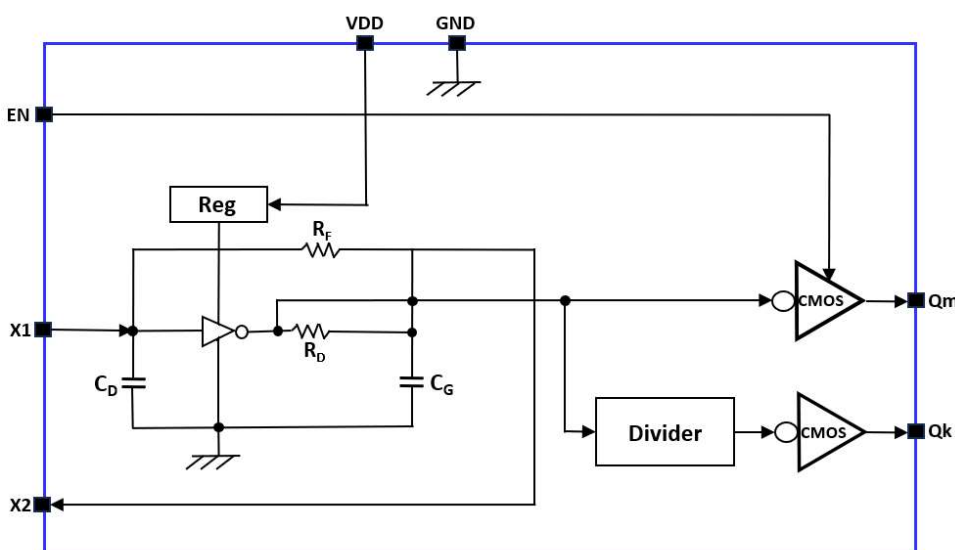

Description

The XO630x is a Low Power double output production. The part generates MHz output and 32.768KHz output from a crystal.

Mode function available: Single output (32.768kHz) or Dual output (32.768kHz+MHz) is selectable.

Function table:

EN pin	32.768KHz	MHz
Level H	Output On	Output On
Level L	Output On	Output Hi-z

Order Information

Part no.	Package type
RS1XOS630xZAE	DFN2*2-8L

Note: X: 1-24MHz input;2-25MHz input; 3-26MHz



Pad Configuration

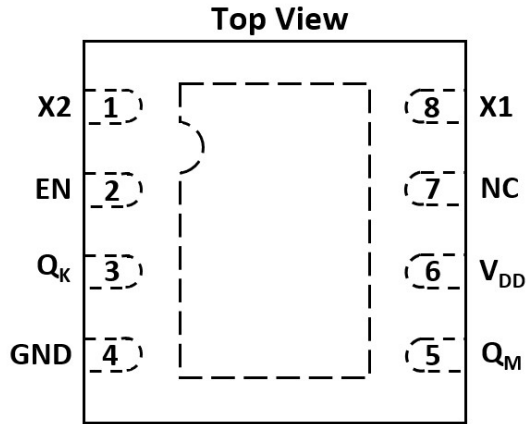

Pad Description

Pad Name	I/O Type	Description
EN	I	Output Mode Select. EN=H: Q _M ON, Q _K ON; EN=L: Q _M Hi-z, Q _K ON.
X1	I	Crystal input pad.
X2	O	Crystal output pad.
GND	GND	Ground.
Q _M	O	MHz Clock output
Q _K	O	32.768KHz Clock output.
VDD	Power	Power supply.



Maximum Rating

Supply Voltage to Ground Potential.....	4V
All Inputs and Output.....	V _{DD} +0.5V
Storage Temperature.....	-65°C to +150°C

Note:

Stresses greater than those listed under MAXIMUM RATINGS may cause permanent damage to the device. This is a stress rating only and functional operation of the device at these or any other conditions above those indicated in the operational sections of this specification is not implied. Exposure to absolute maximum rating conditions for extended periods may affect reliability.

Recommended Operating Conditions

(GND=0V, unless otherwise noted.)

Sym.	Parameter	Conditions	Min	Typ	Max	Unit
V _{DD}	Supply voltage	-	1.62	-	3.63	V
T _A	Operating temperature	-	-40		+85	°C
f ₀	Oscillation frequency* ¹	-		24/25/26		MHz

DC Characteristics

V_{DD}= 1.62V to 3.63V, Ambient Temperature -40 to +85°C

Sym.	Parameter	Conditions	Min.	Typ.	Max.	Unit
V _{DD}	Operating voltage	-	1.62	-	3.63	V
V _{OH}	Output high voltage	V _{DD} =1.8V, IOH = -1mA	V _{DD} -0.4	-	-	V
		V _{DD} =2.5V, IOH = -1mA	V _{DD} -0.4	-	-	V
		V _{DD} =3.3V, IOH = -1mA	V _{DD} -0.4	-	-	V
V _{OL}	Output low voltage	V _{DD} =1.8V, IOH = 1mA	-	-	0.4	V
		V _{DD} =2.5V, IOH = 1mA	-	-	0.4	V
		V _{DD} =3.3V, IOH = 1mA	-	-	0.4	V
V _{IH}	HIGH level input voltage	OE Measurement	0.7V _{DD}			
V _{IL}	LOW level input voltage	OE Measurement			0.3V _{DD}	
I _{DD1}	Supply current1	V _{DD} =1.8V, OE=V _{DD} , Load=15pf		2	4	mA
		V _{DD} =2.5V, OE=V _{DD} , Load=15pf		2.5	5	mA
		V _{DD} =3.3V, OE=V _{DD} ; Load=15pf		3.0	6	mA
I _{DD2}	Supply current2	V _{DD} =1.8V, OE=GND, Load=15pf		63	120	μA
		V _{DD} =2.5V, OE=GND, Load=15pf		63	120	uA
		V _{DD} =3.3V, OE=GND, Load=15pf		66	130	uA



AC Characteristics

V_{DD}= 1.62V to 3.63V, Ambient Temperature -40 to +85°C

Sym.	Parameter	Conditions	Min.	Typ.	Max.	Unit
X _{IN} , X _{OUT}	Crystal input frequency range			24/25/26		MHz
T _{Rise1_MHz}	Output rise time	Measured from 20% to 80% V _{DD} =1.8V, Load=15pf		1.6	2.5	ns
		Measured from 10% to 90% V _{DD} =2.5V, Load=15pf		1.6	2.5	ns
		Measured from 10% to 90% V _{DD} =3.3V, Load=15pf		1.2	2	ns
T _{Fall1_MHz}	Output fall time	Measured from 80% to 20% V _{DD} =1.8V, Load=15pf		1.9	3	ns
		Measured from 90% to 10% V _{DD} =2.5V, Load=15pf		1.7	3	ns
		Measured from 90% to 10% V _{DD} =3.3V, Load=15pf		1.3	2	ns
T _{Rise2_32.768KHz}	Output rise time	Measured from 20% to 80% V _{DD} =1.8V, Load=15pf		5.0	8	ns
		Measured from 10% to 90% V _{DD} =2.5V, Load=15pf		7.0	10	ns
		Measured from 10% to 90% V _{DD} =3.3V, Load=15pf	-	7.0	10	ns
T _{Fall2_32.768KHz}	Output fall time	Measured from 80% to 20% V _{DD} =1.8V, Load=15pf		7.0	10	ns
		Measured from 90% to 10% V _{DD} =2.5V, Load=15pf		8.5	12	ns
		Measured from 90% to 10% V _{DD} =3.3V, Load=15pf	-	7.5	10	ns
Duty cycle	Output duty cycle	Load=15pf, 50%VDD	45	50	55	%

Note: Typical condition is on room temperature at 25°



Measurement Circuit

Measurement parameter: I_{DD} , Duty, t_r , t_f

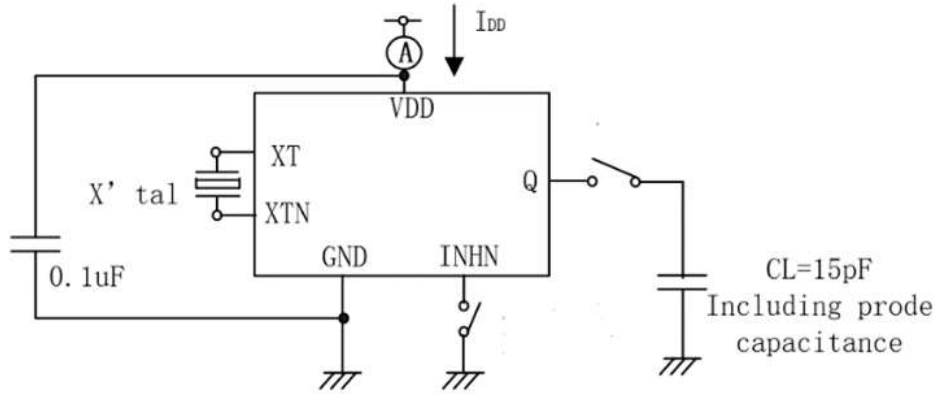

Note: The AC characteristics are observed using an oscilloscope on pin Q

Output waveform

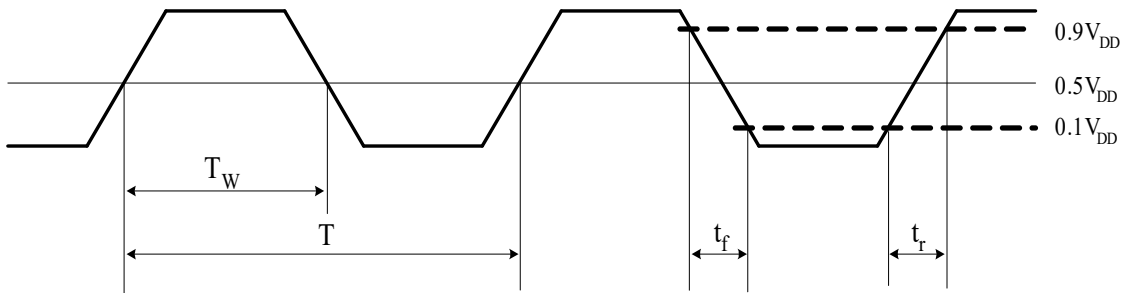

$$\text{DUTY} = T_w / T \times 100 (\%)$$

Revision History

Revision	Description	Date
0	Initial release	2023/5/30
1.0	Updated format and official release	2024/12/06