

## Features

- 1.62 to 3.63V operating supply voltage range  
1.62V to 1.98V for XO5071AA/AN  
1.71V to 1.89V for XO5071AL
- Operating frequency range (varies with version)  
10MHz to 320MHz fundamental oscillation  
60MHz to 290MHz 3rd overtone oscillation
- -40 to 105°C operating temperature range
- Differential LVDS output
- Standby function
- Output is high impedance when OE is LOW (oscillator stops)
- Power-saving pull-up resistor built-in (pin OE)
- CMOS process
- Die form and wafer form

## Applications

- Used for crystal oscillator
- Used for 7050/5032/3225/2520 Package

## Series Configuration

Version	VCC Range	f <sub>output</sub>	Oscillation	Frequency Range* <sup>1</sup>
XO5071A	2.25-3.63	F0	Fundamental	10~70MHz
XO5071AA	1.62-1.98	F0		10~70MHz
XO5071B	2.25-3.63	F0		60~100MHz
XO5071C	2.25-3.63	F0		100~160MHz
XO5071D	2.25-3.63	F0		200~260MHz
XO5071E	2.25-3.63	F0		260MHz~320MHz
XO5071G	2.25-3.63	f0	3rd overtone	60MHz to 90MHz
XO5071H	2.25-3.63	f0		70MHz to 120MHz
XO5071AL	1.71-1.89	f0		120MHz to 160MHz
XO5071AN	1.62-1.98	f0		180MHz to 250MHz
XO5071L	2.25-3.63	f0		120MHz to 180MHz
XO5071N	2.25-3.63	f0		180MHz to 290MHz

### Note:

1. The recommended operating frequency is a yardstick value derived from the crystal used for RSM characteristics authentication. However, the oscillator frequency band is not guaranteed. Specifically, the characteristics can vary greatly due to crystal characteristics and mounting conditions, so the oscillation characteristics of components must be carefully evaluated.

## Description

The XO5071 series are 1.8V/2.5V/3.3V operation, differential LVDS output oscillator ICs. They support 10MHz to 320MHz fundamental and 60MHz to 290MHz 3rd overtone oscillator. The devices are fabricated using a proprietary CMOS process, enabling a high-frequency oscillator circuit and differential LVDS output buffer to be incorporated on a single chip. The XO5071 series can be used to construct high-frequency LVDS output oscillators.

## Ordering Information

Part No.	Package type
XO5071x-yDE	Die form
XO5071x-yWF	Wafer form

### Note:

1. "x" shows the different function. See below table.
2. "-y" shows the die thickness. "3" stands for thickness 130+/-15um
3. "DE" stands for chip form, "WF" stands for Wafer form



## Block Diagram

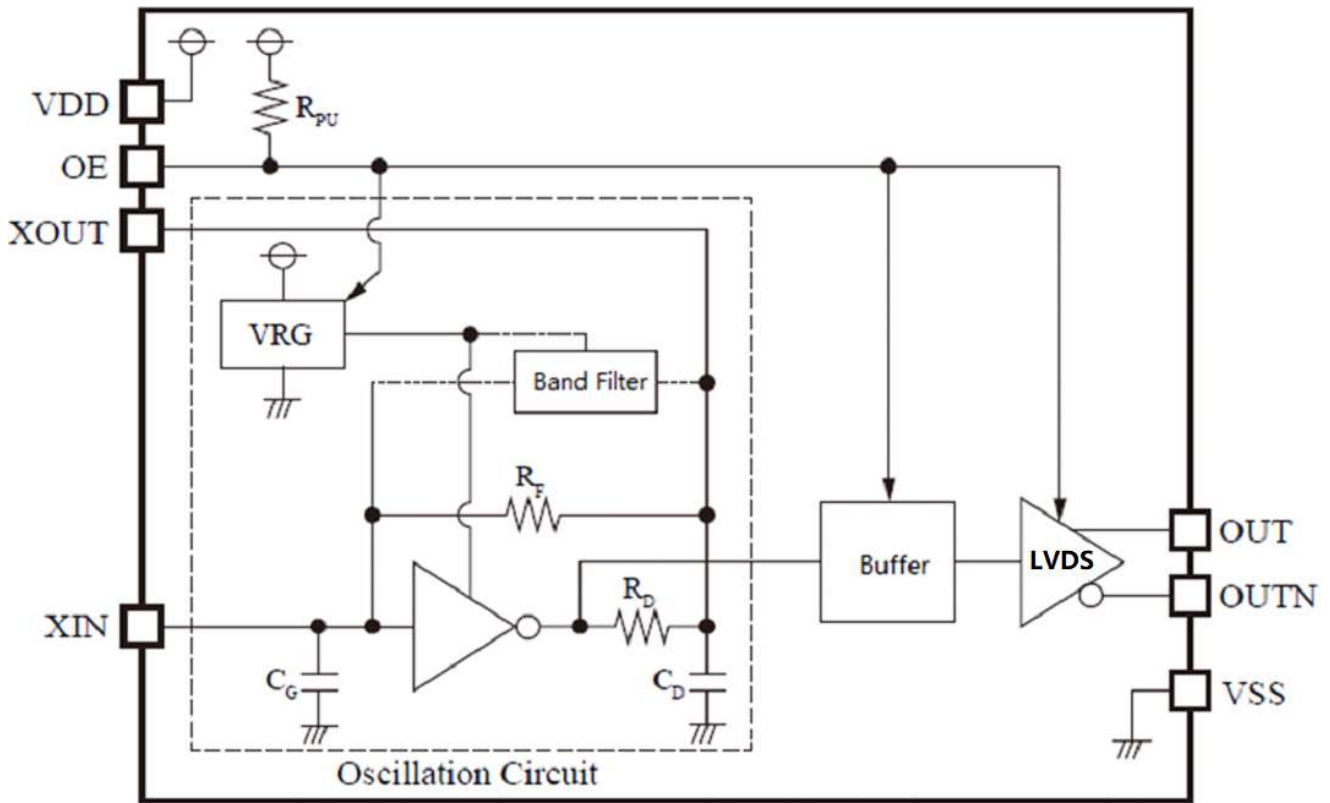



## Pin Configuration

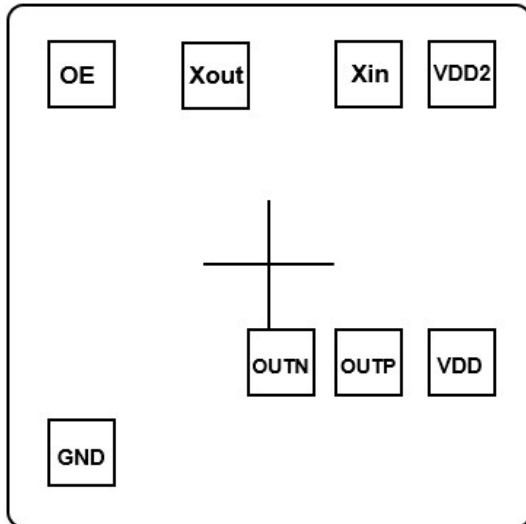

Pad Coordinate					
Pad Name	X Coordinate	Y Coordinate	Pad Name	X Coordinate	Y Coordinate
VDD2	253.995	226.5	OE	-237.27	226.5
XIN	132.125	226.5	OUTN	6.125	-130.165
XOUT	-82.095	226.5	OUTP	132.125	-130.165
GND(VSS)	-225.345	-210.825	VDD	253.995	-130.165

**Note:** Substrate is connected to GND or floating.

**Die Size:** 640um\*580um (Not Including scribe line size 60um\*60um.)

**Pad Size:** 80um\*80um

## Pin Description

Pin Name	Type	Description
VDD VDD2	P	Supply voltage.
XIN	I	Oscillator input pin.
XOUT	O	Oscillator output pin.
GND (VSS)	P	Ground (-).
OE	I	Output enable pin. Output are high impedance when LOW (oscillator stopped). Power-saving pull-up resistor built-in.
OUTN	O	Output pin (complementary).
OUTP	O	Output pin (true).



## Function Description

### Standby Function

When OE goes LOW, the oscillator stops and the output pins (OUT, OUTN) become high impedance.

OE	OUTP/OUTN	Oscillator
HIGH (or open)	f <sub>0</sub>	Normal operation
LOW	High impedance	Stopped

### Power-saving Pull-up Resistor

The OE pin pull-up resistance changes in response to the input level (HIGH or LOW). When OE is tied LOW (standby state), the pull-up resistance becomes large, reducing the current consumed by the resistance. When OE is open circuit, the pull-up resistance becomes small, decreasing the susceptibility to the effects of external noise.

## Absolute Maximum Ratings

Symbol	Parameter	Min	Typ.	Max	Unit
T <sub>store</sub>	Storage Temperature	-65	-	+150	°C
V <sub>DD</sub>	Supply Voltage Range	-0.5	-	5.0	V
V <sub>IN</sub>	Input Voltage Range	-0.5	-	V <sub>DD</sub> +0.5	V
V <sub>OUT</sub>	Output Voltage Range	-0.5	-	V <sub>DD</sub> +0.5	V

### Note:

- Stresses greater than those listed under MAXIMUM RATINGS may cause permanent damage to the device. This is a stress rating only and functional operation of the device at these or any other conditions above those indicated in the operational sections of this specification is not implied. Exposure to absolute maximum rating conditions for extended periods may affect reliability.

## Recommended Operating Conditions

Symbol	Parameter	Conditions	Min	Typ.	Max	Unit
V <sub>DD</sub>	Supply voltage	All XO5071 Except XO5071AL/AN/AA	2.25	-	3.63	V
V <sub>DD</sub>	Supply voltage	XO5071AL	1.71		1.89	V
V <sub>DD</sub>	Supply voltage	XO5071AA/AN	1.62		1.98	V
V <sub>IN</sub>	Input voltage	-	GND	-	V <sub>DD</sub>	V
T <sub>A</sub>	Operating temperature	-	-40	+25	+105	°C
R <sub>L</sub>	Output load		99	100	101	Ω
F <sub>OUT</sub>	Output frequency	fundamental	10	-	320	MHz
		3 <sup>rd</sup> overtone	60		290	MHz



## DC Electrical Characteristics

3.3V operation (VDD = 2.97 to 3.63V, TA = -40 to 105°C, GND = 0V, unless otherwise noted.)

Symbol	Parameter	Conditions	Min	Typ.	Max	Unit
I <sub>EE1</sub>	Current consumption1	Measurement cct.1, OE=Open	-	15	25	mA
I <sub>EE2</sub>	Current consumption2	Measurement cct.1, OE=Low	-	-	30	μA
V <sub>OH</sub>	HIGH-level output voltage	Measurement cct1, OE=Open, RL=100Ω, OUT, OUTN Pins, F=100MHz		1.43	1.6	V
V <sub>OL</sub>	Low Level output Voltage		0.9	1.1		V
V <sub>OD</sub>	Differential output voltage	Measurement cct1, OE=Open, RL=100Ω, OUT, OUTN Pins, F=100MHz	300	400	480	mV
ΔV <sub>OD</sub>	Differential output Error				50	mV
I <sub>Z</sub>	Output leakage current	Measurement cct.3, OE=Low, OUT, OUTN pins	-	-	10	μA
V <sub>IH</sub>	HIGH-level input voltage	Measurement cct.1, OE pin	0.7V <sub>DD</sub>	-	-	V
V <sub>IL</sub>	LOW-level input voltage	Measurement cct.1, OE pin	-	-	0.3V <sub>DD</sub>	V
I <sub>IL1</sub>	LOW-level input current1	Measurement cct.1, V <sub>IL</sub> =0V, OE pin	0	-	-20	μA
I <sub>IL2</sub>	LOW-level input current2	Measurement cct.1, V <sub>IL</sub> =0.7V <sub>DD</sub> , OE pin	-1	-	-150	μA

2.5V operation (VDD = 2.25 to 2.75V, TA = -40 to 105°C, GND = 0V, unless otherwise noted.)

Symbol	Parameter	Conditions	Min	Typ.	Max	Unit
I <sub>EE1</sub>	Current consumption1	Measurement cct.1, OE=Open	-	15	25	mA
I <sub>EE2</sub>	Current consumption2	Measurement cct.1, OE= Low	-	-	30	μA
V <sub>OH</sub>	HIGH-level output voltage	Measurement cct1, OE=Open, RL=100Ω, OUT, OUTN Pins, F=100MHz		1.43	1.6	V
V <sub>OL</sub>	Low Level output Voltage		0.9	1.1		V
V <sub>OD</sub>	Differential output voltage	Measurement cct1, OE=Open, RL=100Ω, OUT, OUTN Pins, F=100MHz	300	400	480	mV
ΔV <sub>OD</sub>	Differential output Error				50	mV
I <sub>Z</sub>	Output leakage current	Measurement cct.3, OE= Low, OUT, OUTN pins	-	-	10	μA
V <sub>IH</sub>	HIGH-level input voltage	Measurement cct.1, OE pin	0.7V <sub>DD</sub>	-	-	V
V <sub>IL</sub>	LOW-level input voltage	Measurement cct.1, OE pin	-	-	0.3V <sub>DD</sub>	V
I <sub>IL1</sub>	LOW-level input current1	Measurement cct.1, V <sub>IL</sub> =0V, OE pin	0	-	-20	μA
I <sub>IL2</sub>	LOW-level input current2	Measurement cct.1, V <sub>IL</sub> =0.7V <sub>DD</sub> , OE pin	-1	-	-150	μA

1.8V operation (VDD = 1.62 to 1.98V, TA = -40 to 105°C, GND = 0V, unless otherwise noted.)

Symbol	Parameter	Conditions	Min	Typ.	Max	Unit
I <sub>EE1</sub>	Current consumption1	Measurement cct.1, OE=Open	-	8	16	mA
I <sub>EE2</sub>	Current consumption2	Measurement cct.1, OE=Low	-	-	30	μA
V <sub>OH</sub>	HIGH-level output voltage	Measurement cct1, OE=Open, RL=100Ω, OUT, OUTN Pins, F=100MHz		0.8	1.0	V
V <sub>OL</sub>	Low Level output Voltage		0.3	0.5		V
V <sub>OD</sub>	Differential output voltage	Measurement cct1, OE=Open, RL=100Ω, OUT, OUTN Pins, F=100MHz	200	300	400	mV
ΔV <sub>OD</sub>	Differential output Error				50	mV
I <sub>Z</sub>	Output leakage current	Measurement cct.3, OE= Low, OUT, OUTN pins	-	-	10	μA
V <sub>IH</sub>	HIGH-level input voltage	Measurement cct.1, OE pin	0.7V <sub>DD</sub>	-	-	V
V <sub>IL</sub>	LOW-level input voltage	Measurement cct.1, OE pin	-	-	0.3V <sub>DD</sub>	V
I <sub>IL1</sub>	LOW-level input current1	Measurement cct.1, V <sub>IL</sub> =0V, OE pin	0	-	-20	μA
I <sub>IL2</sub>	LOW-level input current2	Measurement cct.1, V <sub>IL</sub> =0.7V <sub>DD</sub> , OE pin	-1	-	-150	μA

Note: XO5071AL: VDD=1.71V~1.89V



## AC Electrical Characteristics

3.3V operation ( $V_{DD} = 2.97$  to  $3.63V$ ,  $T_A = -40$  to  $105^\circ C$ ,  $GND = 0V$ , unless otherwise noted.)

Symbol	Parameter	Conditions	Min	Typ.	Max	Unit
Duty1	Output duty cycle1	Measurement cct.4, measured at output crossing point, $T_A=25^\circ C$ , $V_{DD}=3.3V$	45	-	55	%
Duty2	Output duty cycle2	Measurement cct.4, measured at 50% output swing, $T_A=25^\circ C$ , $V_{DD}=3.3V$	45	-	55	%
Vopp	Output swing	Measurement cct.4, $T_A=T_{OPR}$ , Peak to Peak of single output wave	0.35	-	-	V
tr	Output rise time	Measurement cct.4, 20 to 80% output swing	-	0.2	0.35	ns
tf	Output fall time	Measurement cct.4, 80 to 20% output swing	-	0.2	0.35	ns
t <sub>OE</sub>	Output enable time*1	Measurement cct.5, $T_A=25^\circ C$	-	-	2	ms
t <sub>OD</sub>	Output disable time	Measurement cct.5, $T_A=25^\circ C$	-	-	200	ns

2.5V operation ( $V_{DD} = 2.25$  to  $2.75V$ ,  $T_A = -40$  to  $105^\circ C$ ,  $GND = 0V$ , unless otherwise noted.)

Symbol	Parameter	Conditions	Min	Typ.	Max	Unit
Duty1	Output duty cycle1	Measurement cct.4, measured at output crossing point, $T_A=25^\circ C$ , $V_{DD}=2.5V$	45	-	55	%
Duty2	Output duty cycle2	Measurement cct.4, measured at 50% output swing, $T_A=25^\circ C$ , $V_{DD}=2.5V$	45	-	55	%
Vopp	Output swing	Measurement cct.4, $T_A=T_{OPR}$ , Peak to Peak of single output wave	0.3	-	-	V
tr	Output rise time	Measurement cct.4, 20 to 80% output swing	-	0.2	0.35	ns
tf	Output fall time	Measurement cct.4, 80 to 20% output swing	-	0.2	0.35	ns
t <sub>OE</sub>	Output enable time*1	Measurement cct.5, $T_A=25^\circ C$	-	-	2	ms
t <sub>OD</sub>	Output disable time	Measurement cct.5, $T_A=25^\circ C$	-	-	200	ns

1.8V operation ( $V_{DD} = 1.62$  to  $1.98V$ ,  $T_A = -40$  to  $105^\circ C$ ,  $GND = 0V$ , unless otherwise noted.)

Symbol	Parameter	Conditions	Min	Typ.	Max	Unit
Duty1	Output duty cycle1	Measurement cct.4, measured at output crossing point, $T_A=25^\circ C$ , $V_{DD}=1.8V$	45	-	55	%
Duty2	Output duty cycle2	Measurement cct.4, measured at 50% output swing, $T_A=25^\circ C$ , $V_{DD}=1.8V$	45	-	55	%
Vopp	Output swing	Measurement cct.4, Peak to Peak of single output wave, 5071AL: $f=156.25MHz$	0.2	-	-	V
tr	Output rise time	Measurement cct.4, 20 to 80% output swing	-	0.2	0.35	ns
tf	Output fall time	Measurement cct.4, 80 to 20% output swing	-	0.2	0.35	ns
t <sub>OE</sub>	Output enable time*1	Measurement cct.5, $T_A=25^\circ C$	-	-	2	ms
t <sub>OD</sub>	Output disable time	Measurement cct.5, $T_A=25^\circ C$	-	-	200	ns

### Note:

1. The built-in oscillator stop function does not operate with normal output immediately when OE goes HIGH. Instead, normal output occurs after the oscillator startup time has elapsed.
2. XO5071AL:  $V_{DD}=1.71V\sim 1.89V$



## Timing chart

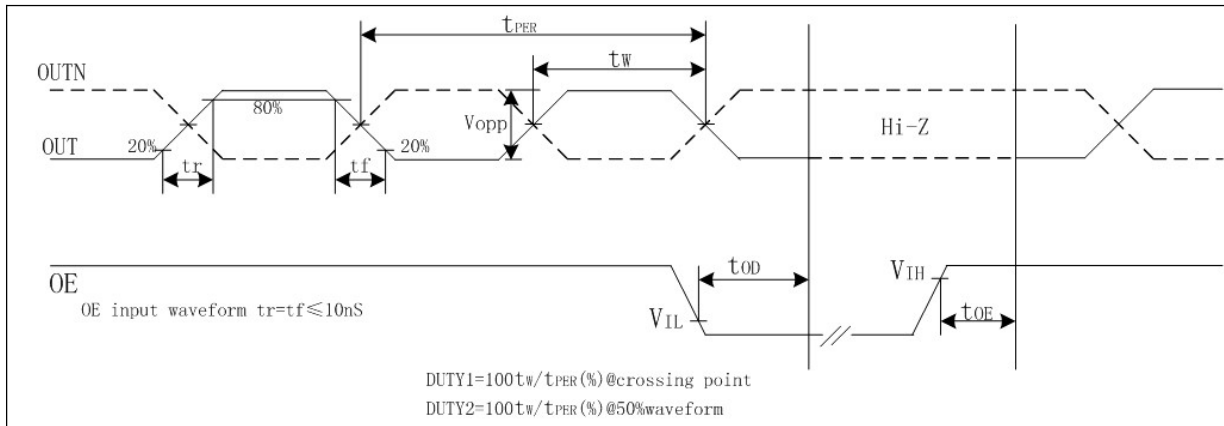



## Measurement Circuit

**Measurement Circuit 1: I<sub>EE1</sub>, I<sub>EE2</sub>, V<sub>IH</sub>, V<sub>IL</sub>, R<sub>PU1</sub>, R<sub>PU2</sub>**

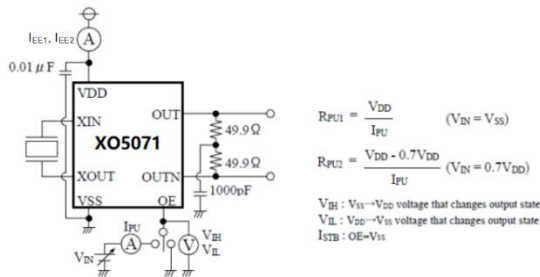

**Measurement Circuit 4: Duty1, Duty2, V<sub>OPP</sub>, t<sub>r</sub>, t<sub>f</sub>**

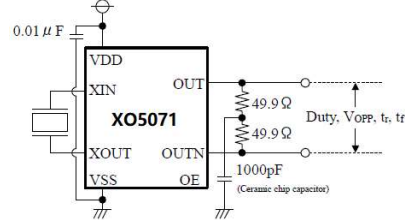

**Measurement Circuit 2: V<sub>OL</sub>, V<sub>OH</sub>**

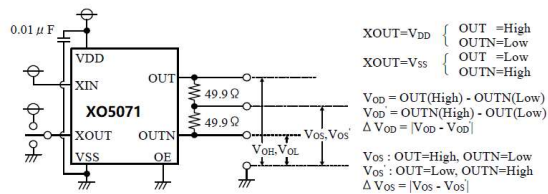

**Measurement Circuit 5: t<sub>OD</sub>**

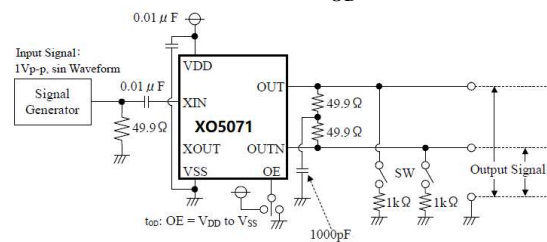

**Measurement Circuit 3: I<sub>Z</sub>**

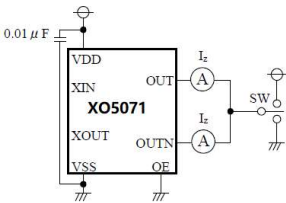

## Reference Data

The following characteristics are measured using the crystal below. Note that the characteristics will vary with the crystal used.

Parameter	f <sub>0</sub> =125.00MHz	f <sub>0</sub> =156.25MHz
C0(pF)	1.8	1.2
R1(Ω)	35	60

Crystal parameters

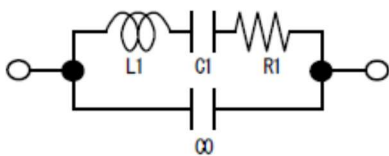





## Revision History

Revision	Description	Date
V5.3	Updated limit for IEE1 / IIL	2023/2/17
V5.4	1. Update Tr and Tf 2. Update XO5071A frequency range	2023/6/6
V5.5	Update XO5071L Frequency range	2023/7/17
V5.6	1. Update XO5071N frequency range 2. Add XO5071AN 3. Delete XO5071M	2023/8/2
V5.7	1. Update XO5071N frequency range to 290MHz	2023/9/22
V5.8	1. Add application for SMD2520 package	2024/6/5
V5.9	1. Change XO5071AL/AN operating volage range from 1.62V~1.98V to 1.71V~1.89V	2024/8/16
V6.0	1. Add XO5071AA, operating volage range from 1.62V to1.98V 2. Updated XO5071AN operating voltage is 1.62V~1.98V	2024/9/9