



Features

- 2.25 to 3.63V operating supply voltage range
- Operating frequency range (varies with version)
10MHz to 320MHz fundamental oscillation
60MHz to 290MHz 3rd overtone oscillation
- -40 to 105°C operating temperature range
- Differential LVPECL output
- 50Ω output load (terminated to V_{DD}-2V)
- Standby function: Output are high impedance when OE is LOW (oscillator stops)
- Power-saving pull-up resistor built-in (pin OE)
- CMOS process
- Die form and wafer form

Applications

- Used for crystal oscillator
- Used for 7050/5032/3225/2520 Package

Description

The XO5070 series are 2.5V/3.3V operation, differential LVPECL output oscillator ICs. They support 10MHz to 320MHz fundamental and 60MHz to 290MHz 3rd overtone oscillator. The devices are fabricated using a proprietary CMOS process, enabling a high-frequency oscillator circuit and differential LVPECL output buffer to be incorporated on a single chip. The XO5070 series can be used to construct high-frequency LVPECL output oscillators.

Ordering Information

Part no.	Package type
XO5070x-yDE	Die form
XO5070x-yWF	Wafer form

Note:

- 1."x" shows the different function. See below table.
2. "-y" shows the die thickness." "-3" Stand for thickness 130+/-15um
3. "DE" stands for chip form, "WF" stands for Wafer form

Series Configuration

Version	f _{output}	Oscillation	Frequency Range ^{*1}
XO5070A	F0	Fundamental	10~70MHz
XO5070B	F0		60~100MHz
XO5070C	F0		100~160MHz
XO5070D	F0		200~260MHz
XO5070E	F0		260MHz~320MHz
XO5070G	f0	3 rd overtone	60MHz to 90MHz
XO5070H	f0		70MHz to 120MHz
XO5070L	f0		120MHz to 180MHz
XO5070N	f0		180MHz to 290MHz

Note: * 1. The recommended operating frequency is a yardstick value derived from the crystal used for RSM characteristics authentication. However, the oscillator frequency band is not guaranteed. Specifically, the characteristics can vary greatly due to crystal characteristics and mounting conditions, so the oscillation characteristics of components must be carefully evaluated.



Block Diagram

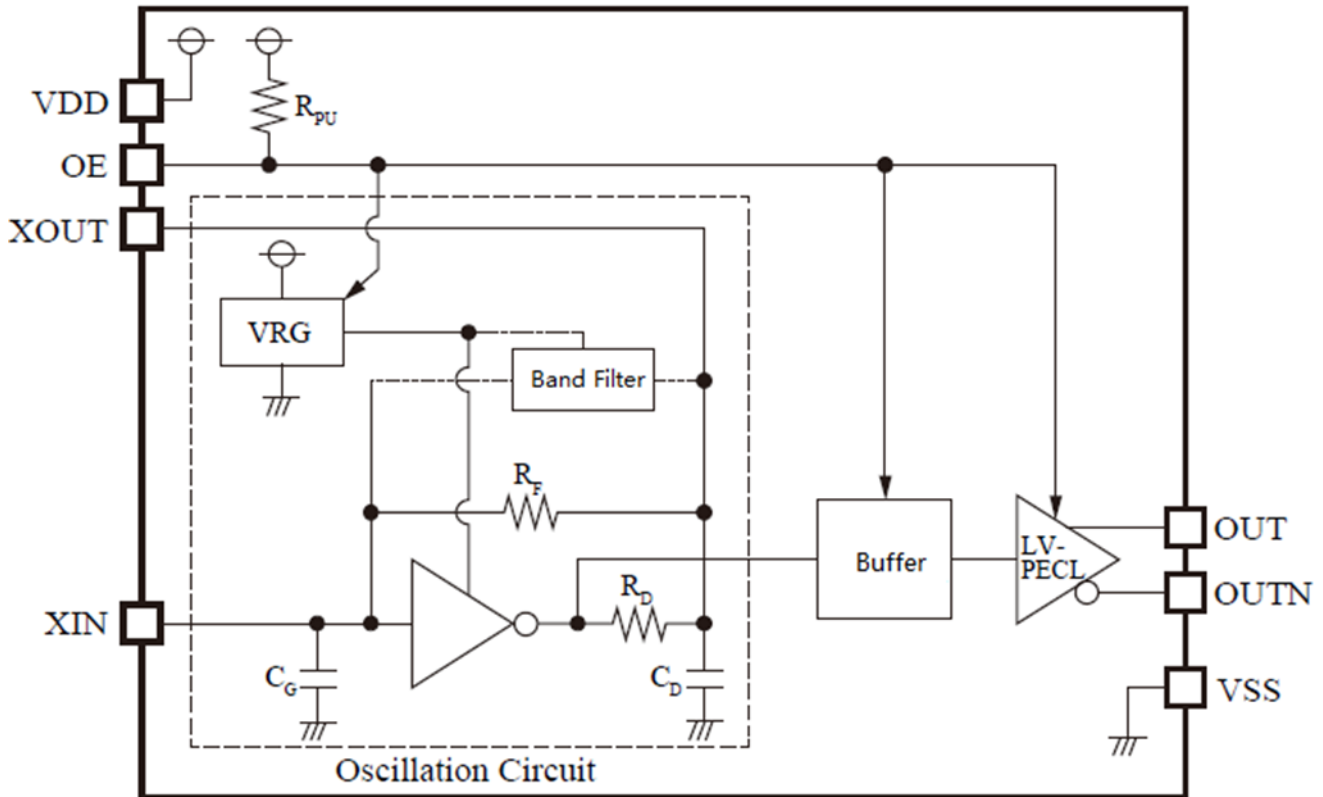



Pad Configuration

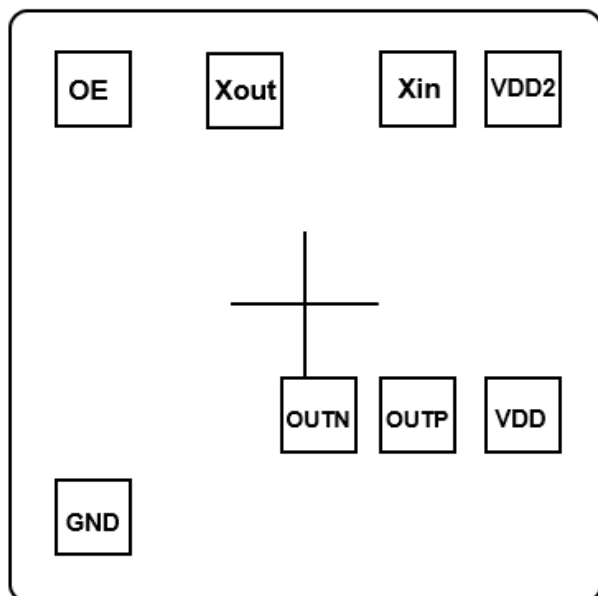

Pad Coordinate File

Pad Name	X Coordinate	Y Coordinate	Pad Name	X Coordinate	Y Coordinate
VDD2	253.995	226.5	OE	-237.27	226.5
XIN	132.125	226.5	OUTN	6.125	-130.165
XOUT	-82.095	226.5	OUTP	132.125	-130.165
GND(VSS)	-225.345	-210.825	VDD	253.995	-130.165

Note: Substrate is connected to GND or floating.

Die Size: 640um*580um (Not Including scribe line size 60um*60um.)

Pad Size: 80um*80um

Pad Description

Sym.	Type	Description
VDD VDD2	P	Supply voltage.
XIN	I	Oscillator input pin.
XOUT	O	Oscillator output pin.
GND (VSS)	P	Ground (-).
OE	I	Output enable pin. Output are high impedance when LOW (oscillator stopped). Power-saving pull-up resistor built-in.
OUTN	O	Output pin (complementary).
OUTP	O	Output pin (true).



Function Description

Standby Function

When OE goes LOW, the oscillator stops and the output pins (OUT, OUTN) become high impedance.

OE	OUT ,OUTN	Oscillator
HIGH (or open)	f0	Normal operation
LOW	High impedance	Stopped

Power-saving Pull-up Resistor

The OE pin pull-up resistance changes in response to the input level (HIGH or LOW). When OE is tied LOW (standby state), the pull-up resistance becomes large, reducing the current consumed by the resistance. When OE is open circuit, the pull-up resistance becomes small, decreasing the susceptibility to the effects of external noise.

Absolute Maximum Ratings

Symbol	Parameter	MIN	TYP	MAX	Unit
T _{store}	Storage Temperature	-65	-	+150	°C
V _{DD}	Supply Voltage Range	-0.5	-	5.0	V
V _{IN}	Input Voltage Range	-0.5	-	V _{DD} +0.5	V
V _{OUT}	Output Voltage Range	-0.5	-	V _{DD} +0.5	V

Note:

- Stresses greater than those listed under MAXIMUM RATINGS may cause permanent damage to the device. This is a stress rating only and functional operation of the device at these or any other conditions above those indicated in the operational sections of this specification is not implied. Exposure to absolute maximum rating conditions for extended periods may affect reliability.

Recommended Operating Conditions

Sym.	Parameter	Conditions	Min	Typ	Max	Unit
V _{DD}	Supply voltage	-	2.25	-	3.63	V
V _{IN}	Input voltage	-	GND	-	V _{DD}	V
T _A	Operating temperature	XO5070x	-40	+25	+105	°C
R _L	Output load	Terminated to V _{DD} -2V	49.5	50	50.5	Ω
F _{OUT}	Output frequency	fundamental	10	-	320	MHz
		3 rd overtone	60	-	290	MHz



DC Electrical Characteristics

3.3V operation ($V_{DD} = 2.97$ to $3.63V$, $T_A = -40$ to $105^\circ C$, $GND = 0V$, unless otherwise noted.)

Symbol	Parameter	Conditions	Min	Typ	Max	Unit
I_{EE1}	Current consumption1	Measurement cct.1, OE=open	-	40	60	mA
I_{EE2}	Current consumption2	Measurement cct.1, OE=LOW	-	-	30	μA
V_{OH}	HIGH-level output voltage	Measurement cct.2, $V_{DD}=3.3V$, OE=open, OUT, OUTN pins	2.2	2.4	2.6	V
V_{OL}	LOW-level output voltage		1.4	1.6	1.8	V
I_Z	Output leakage current	Measurement cct.3, OE=LOW, OUT, OUTN pins	-	-	10	μA
V_{IH}	HIGH-level input voltage	Measurement cct.1, OE pin	$0.7V_{DD}$	-	-	V
V_{IL}	LOW-level input voltage	Measurement cct.1, OE pin	-	-	$0.3V_{DD}$	V
I_{IL1}	LOW-level input current1	Measurement cct.1, $V_{IL}=0V$, OE pin	0	-	-20	μA
I_{IL2}	LOW-level input current2	Measurement cct.1, $V_{IL}=0.7V_{DD}$, OE pin	-1	-	-150	μA

2.5V operation ($V_{DD} = 2.25$ to $2.75V$, $T_A = -40$ to $105^\circ C$, $GND = 0V$, unless otherwise noted.)

Symbol	Parameter	Conditions	Min	Typ	Max	Unit
I_{EE1}	Current consumption1	Measurement cct.1, OE=open	-	38	60	mA
I_{EE2}	Current consumption2	Measurement cct.1, OE=LOW	-	-	30	μA
V_{OH}	HIGH-level output voltage	Measurement cct.2, $V_{DD}=2.5V$, OE=open, OUT, OUTN pins	1.4	1.6	1.8	V
V_{OL}	LOW-level output voltage		0.6	0.8	1.0	V
I_Z	Output leakage current	Measurement cct.3, OE=LOW, OUT, OUTN pins	-	-	10	μA
V_{IH}	HIGH-level input voltage	Measurement cct.1, OE pins	$0.7V_{DD}$	-	-	V
V_{IL}	LOW-level input voltage	Measurement cct.1, OE pins	-	-	$0.3V_{DD}$	V
I_{IL1}	LOW-level input current1	Measurement cct.1, $V_{IL}=0V$, OE pins	0	-	-20	μA
I_{IL2}	LOW-level input current2	Measurement cct.1, $V_{IL}=0.7V_{DD}$, OE pins	-1	-	-150	μA



AC Electrical Characteristics

3.3V operation ($V_{DD} = 2.97$ to $3.63V$, $T_A = -40$ to $105^\circ C$, $GND = 0V$, unless otherwise noted.)

Symbol	Parameter	Conditions	Min	Typ	Max	Unit
Duty1	Output duty cycle1	Measurement cct.4, measured at output crossing point, $T_A=25^\circ C$, $V_{DD}=3.3V$	45	-	55	%
Duty2	Output duty cycle2	Measurement cct.4, measured at 50% output swing, $T_A=25^\circ C$, $V_{DD}=3.3V$	45	-	55	%
Vopp	Output swing	Measurement cct.4, Peak to Peak of single output wave	0.6	0.8	-	V
tr	Output rise time	Measurement cct.4, 20 to 80% output swing	-	0.2	0.4	ns
tf	Output fall time	Measurement cct.4, 80 to 20% output swing	-	0.2	0.4	ns
t _{OE}	Output enable time*1	Measurement cct.5, $T_A=25^\circ C$	-	-	2	ms
t _{OD}	Output disable time	Measurement cct.5, $T_A=25^\circ C$	-	-	200	ns

2.5V operation ($V_{DD} = 2.25$ to $2.75V$, $T_A = -40$ to $105^\circ C$, $GND = 0V$, unless otherwise noted.)

Symbol	Parameter	Conditions	Min	Typ	Max	Unit
Duty1	Output duty cycle1	Measurement cct.4, measured at output crossing point, $T_A=25^\circ C$, $V_{DD}=2.5V$	45	-	55	%
Duty2	Output duty cycle2	Measurement cct.4, measured at 50% output swing, $T_A=25^\circ C$, $V_{DD}=2.5V$	45	-	55	%
Vopp	Output swing	Measurement cct.4, Peak to Peak of single output wave	0.5	0.7	-	V
tr	Output rise time	Measurement cct.4, 20 to 80% output swing	-	0.25	0.5	ns
tf	Output fall time	Measurement cct.4, 80 to 20% output swing	-	0.25	0.5	ns
t _{OE}	Output enable time*1	Measurement cct.5, $T_A=25^\circ C$	-	-	2	ms
t _{OD}	Output disable time	Measurement cct.5, $T_A=25^\circ C$	-	-	200	ns

Note: *1: The built-in oscillator stop function does not operate with normal output immediately when OE goes HIGH. Instead, normal output occurs after the oscillator startup time has elapsed.

Timing chart

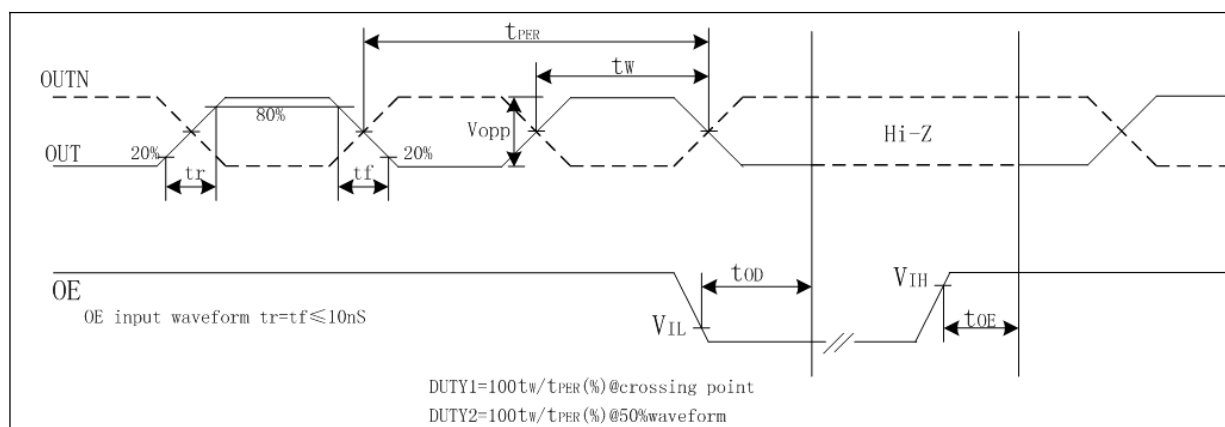



Measurement Circuit

Measurement Circuit 1: I_{EE1} , I_{EE2} , V_{IH} , V_{IL} , R_{PU1} , R_{PU2}

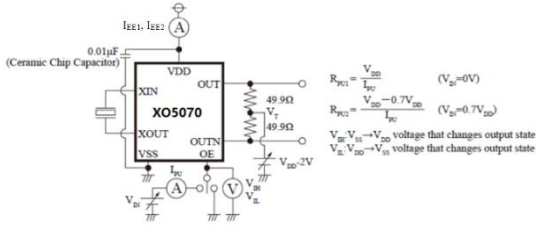

Measurement Circuit 4: Duty1, Duty2, V_{OPP} , t_r , t_f

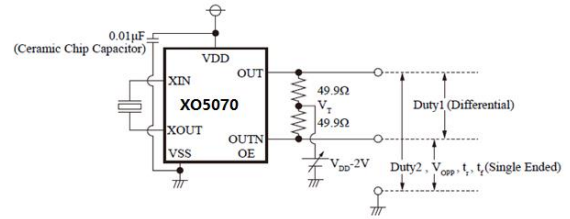

Measurement Circuit 2: V_{OL} , V_{OH}

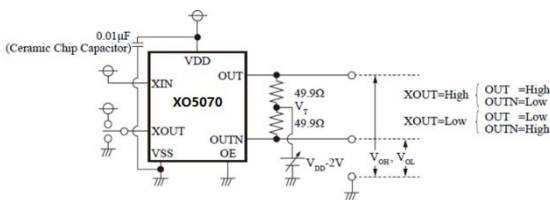

Measurement Circuit 5: t_{OD}

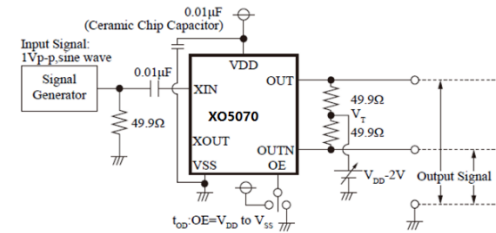

Measurement Circuit 3: I_Z

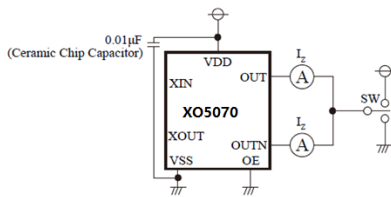

Reference Data

The following characteristics are measured using the crystal below. Note that the characteristics will vary with the crystal used.

Parameter	$f_0=125.00MHz$	$f_0=156.25MHz$
C0(pF)	1.8	1.2
R1(Ω)	35	60

Crystal parameters

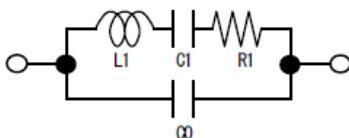



History Log:

Revision	Description	Date
V5.3	Update limit for IEE1/VOH/VOL/IIL	2023/2/17
V5.4	Update XO5070L frequency range	2023/7/19
V5.5	1. Update XO5070A and XO5070N frequency range, 2. Delete XO5070M	2023/8/2
V5.6	1. Updated XO5070N Frequency range	2023/9/22
V5.7	1. Add application for SMD2520 package	2024/6/5