



Features

- Precision supply-voltage monitor
 - 4.63V (RS809L)
 - 4.38V (RS809M)
 - 4.00V (RS809J)
 - 3.08V (RS809T)
 - 2.93V (RS809S)
 - 2.63V (RS809R)
 - 2.32V (RS809Z)
 - 1.63V (RS809X)
- 200ms(min) reset pulse width
- Push-Pull /RESET Output Configurations for RS809
- 9µA Supply Current
- Guaranteed Reset(/Reset) Valid to $V_{CC} = +1.0V$
- Power Supply Transient Immunity
- No External Components

Ordering Information

Part Number	Package
RS809xTE	Lead free and Green SOT23-3

Note: “x” refers to voltage range, see below table.
 “T” stands for SOT23 Package
 “E” stands for Lead free and Green

Suffix: x—Monitored Voltage

x	L	M	J	T	S	R	Z	X
Reset Threshold (V)	4.63	4.38	4.0	3.08	2.93	2.63	2.32	1.63

Block Diagram

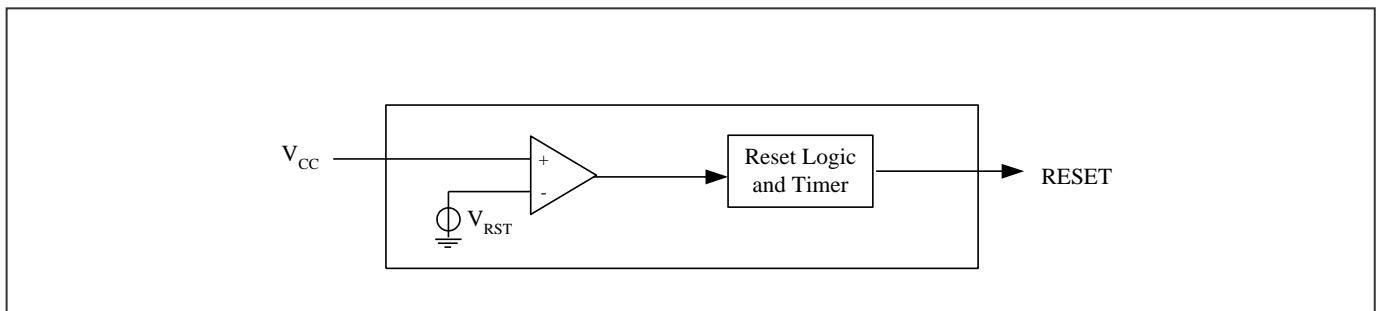

Description

The RS809 are microprocessor (μP) supervisory circuits used to monitor the power supplies in μP and digital systems. They provide excellent circuit reliability and low cost by eliminating external components and adjustments when used with +3.3V, +3.0V, or 2.5V, 1.8V powered circuits.

These circuits perform a single function: they assert a reset signal whenever the VCC supply voltage declines below a preset threshold, keeping it asserted for at least 200ms after VCC has risen above the reset threshold. Reset thresholds suitable for operation with a variety of supply voltages are available.

The RS809 have push-pull outputs and have an active-low /RESET output. The reset comparator is designed to ignore fast transients on V_{CC} , and the outputs are guaranteed to be in the correct logic state for V_{CC} down to 1V.

Low supply current makes the RS809 ideal for use in portable equipment. The ICs are available in 3 pin SOT23 packages.



Pin Configuration

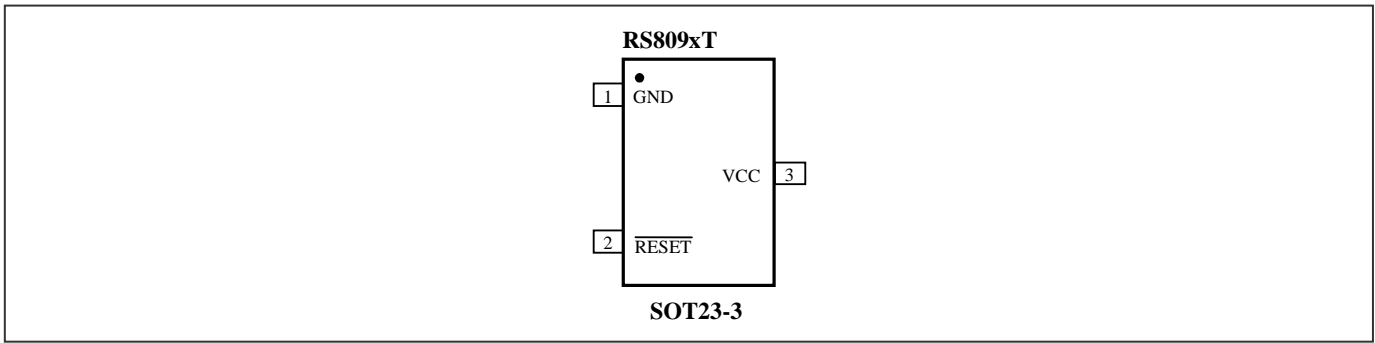

Pin Description

Pin	Type	Description
VCC	-	Supply Voltage. Reset is asserted when V _{CC} drops below the Reset Threshold Voltage (V _{RST}). Reset remains asserted until V _{CC} rises above V _{RST} and keep asserted for the duration of the Reset Timeout Period (t _{RS}) once V _{CC} rises above V _{RST} .
GND	-	Ground
$\overline{\text{RESET}}$	O	Active-Low Reset Output (Push-Pull). It goes low when Vcc is below the reset threshold. It remains low for about 240ms after Vcc rises above the reset threshold (V _{RST}).

Functional Description

Reset Output

A microprocessor (μP) reset input starts the μP in a known state. Whenever the μP is in an unknown state, it should be held in reset. The supervisory circuits assert reset during power-up and prevent code execution errors during power-down or brownout conditions.

On power-up, once Vcc reaches about 1.0V, $\overline{\text{RESET}}$ is a guaranteed logic low of 0.4V or less. As Vcc rises, $\overline{\text{RESET}}$ stays low. When Vcc rises above the reset threshold, an internal timer releases $\overline{\text{RESET}}$ after about 240ms. $\overline{\text{RESET}}$ pulses low whenever Vcc drops below the reset threshold, i.e. brownout condition. If brownout occurs in the middle of a previously initiated reset pulse, the pulse continues for at least another 240ms. On power-down, once Vcc falls below the reset threshold, $\overline{\text{RESET}}$ stays low and is guaranteed to be 0.4V or less until Vcc drops below 1.0V. *Reset Timing Diagram* shows the timing relationship.



Typical Application Circuit

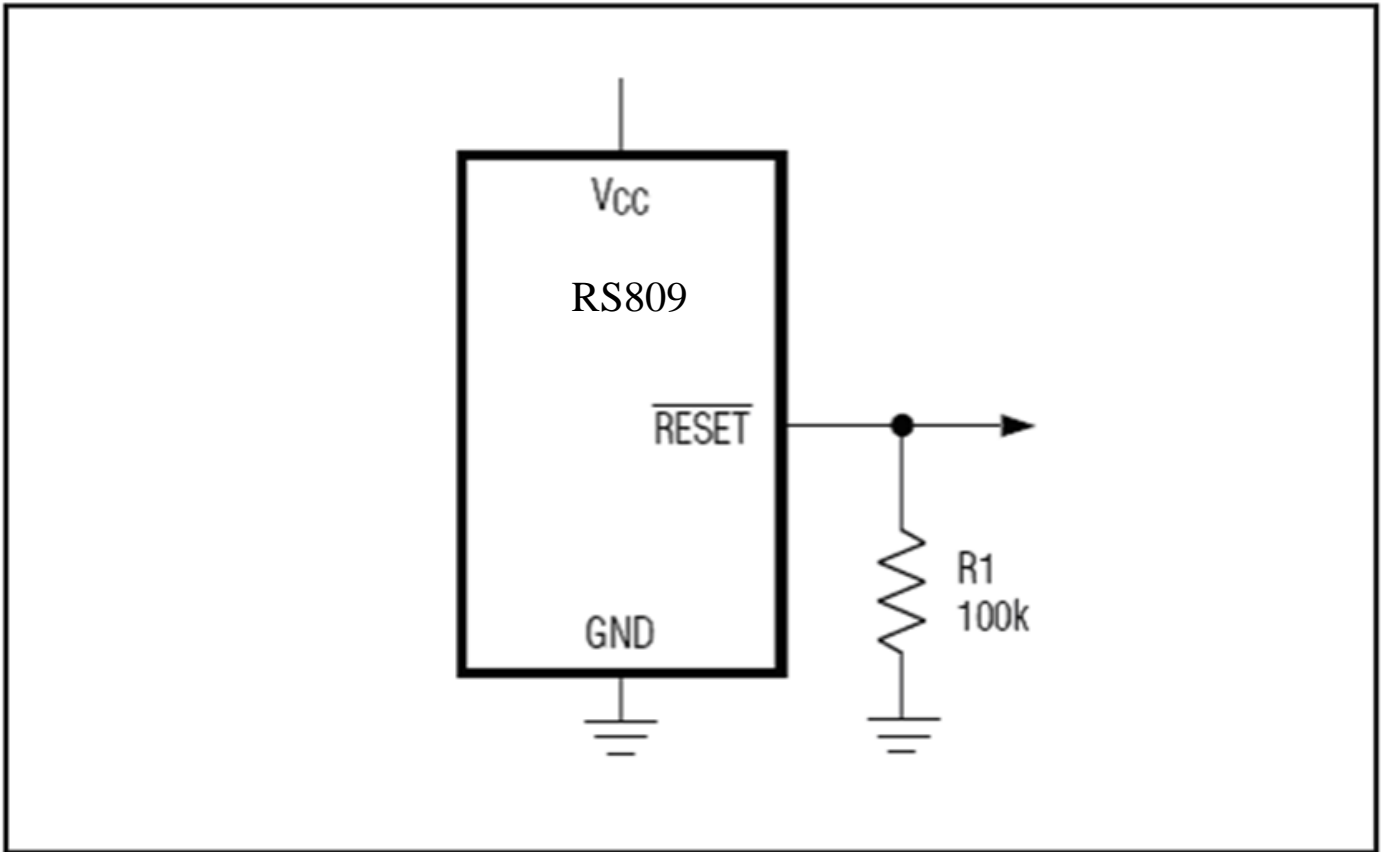



Maximum Ratings

Storage Temperature	-55°C to +150°C
Ambient Temperature with Power Applied.....	-40°C to +85°C
Supply Voltage to Ground Potential (Vcc to GND)	-0.3V to +6.0V
DC Input Voltage (All inputs except Vcc and GND).....	-0.3V to V _{CC} +0.3V
DC Output Current (All outputs)	20mA
Power Dissipation	320mW

Note:

Stresses greater than those listed under MAXIMUM RATINGS may cause permanent damage to the device. This is a stress rating only and functional operation of the device at these or any other conditions above those indicated in the operational sections of this specification is not implied. Exposure to absolute maximum rating conditions for extended periods may affect reliability.

Recommended Operation Conditions

Sym	Description	Test Conditions	Min	Typ	Max	Unit
V _{CC}	Supply Voltage for RS809(L/M)	-	4.5	5.0	5.5	V
	Supply Voltage for RS809(T/S)	-	3.0	3.3	5.5	V
	Supply Voltage for RS809(R)	-	2.8	3.0	5.5	V
	Supply for RS809(Z)	-	2.5	-	5.5	V
	Supply for RS809(X)	-	1.8	-	-	-
T _A	Operating Temperature	-	-40	-	85	°C



DC Electrical Characteristics

($V_{CC} = V_{RN} + 5\%$ to 5.5V, $T_A = -40 \sim 85^\circ\text{C}$, unless otherwise noted.)(Note 1)

Symbol	Description	Test Conditions		Min	Typ	Max	Unit
V_{CC}	Operating Voltage Range	-		1.0	-	5.5	V
I_{CC}	Supply Current	$V_{CC} < 5.5\text{V}$, RS8xxL/M		-	10	30	μA
I_{CC}	Supply Current	$V_{CC} < 3.6\text{V}$, RS8xxR/S/T/Z		-	10	30	
V_{RST}	Threshold voltage(Falling Edge) Note 2	$T_A = 25^\circ\text{C}$	RS809L~Z	$V_{RN} - 1.5\%$	V_{RN}	$V_{RN} + 1.5\%$	V
		$T_A = -40 \sim 85^\circ\text{C}$	RS809L~X	$V_{RN} - 2.5\%$	V_{RN}	$V_{RN} + 2.5\%$	
V_{OH}	Output High Voltage	$V_{CC} \geq 4.5\text{V}$ $I_{source} = 800\mu\text{A}$		$V_{CC} - 1.5$	-	-	V
		$V_{CC} \geq 2.7\text{V}$ $I_{source} = 500\mu\text{A}$		$0.8 \times V_{CC}$	-	-	
		$V_{CC} \geq 1.8\text{V}$ $I_{source} = 150\mu\text{A}$		$0.8 \times V_{CC}$	-	-	
		$V_{CC} \geq 1.0\text{V}$ $I_{source} = 4\mu\text{A}$		$0.8 \times V_{CC}$	-	-	
V_{OL}	Output Low Voltage	$V_{CC} \geq 4.5\text{V}$ $I_{sink} = 3.2\text{mA}$		-	-	0.4	V
		$V_{CC} \geq 2.7\text{V}$ $I_{sink} = 1.2\text{mA}$		-	-	0.3	
		$V_{CC} \geq 1.0\text{V}$ $I_{sink} = 100\mu\text{A}$		-	-	0.3	

Note: 1. Parameters of room temperature guaranteed by production test and parameters of full-temperature guaranteed by design.
2. V_{RST} is Reset threshold voltage when V_{CC} falls from high to low level. V_{RN} is nominal reset threshold voltage.

AC Electrical Characteristics

Symbol	Description	Test Conditions		Min	Typ	Max	Unit
t_{RS}	Reset Time	$T_A = -40 \sim 85^\circ\text{C}$	RS809L~X	200	240	400	ms

Reset Timing Diagram

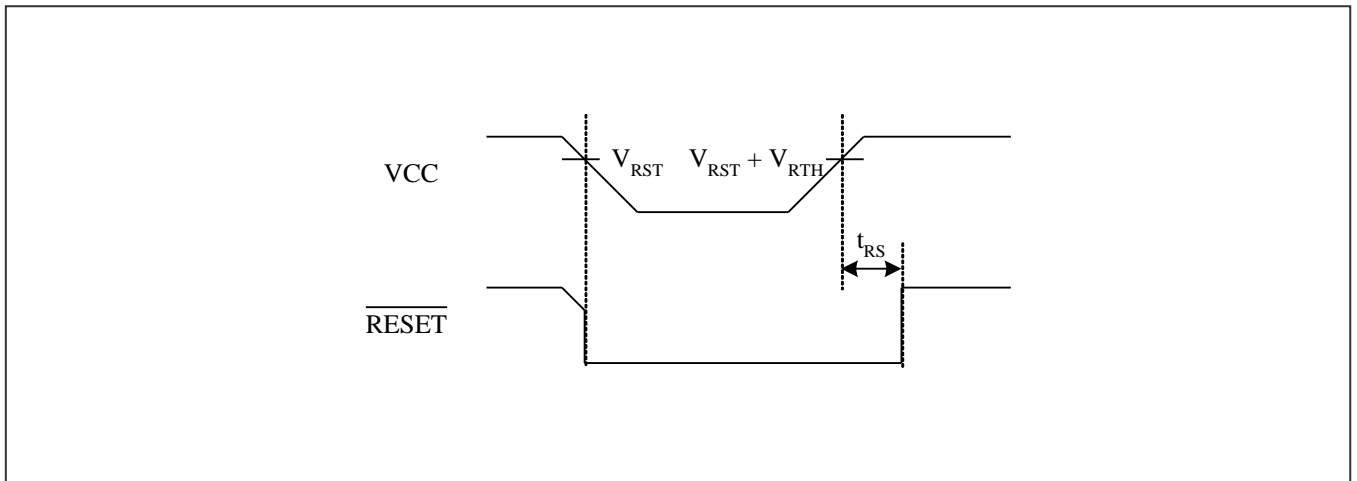



Mechanical Information

TE (Lead free and Green SOT23-3)

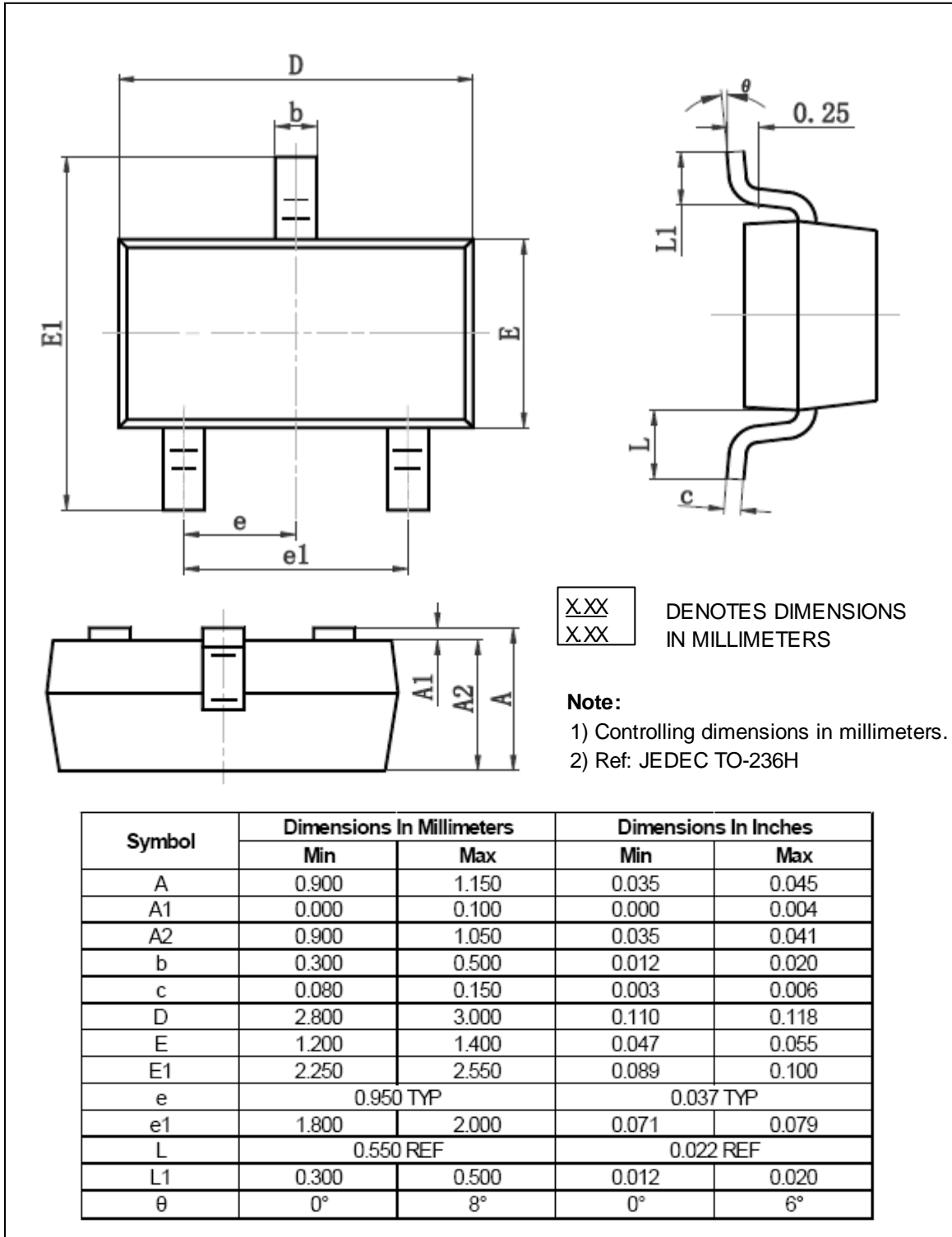



Notes